

OPTicoat ST30

Spin Coating System with “Covered Chuck”

Operating Instructions

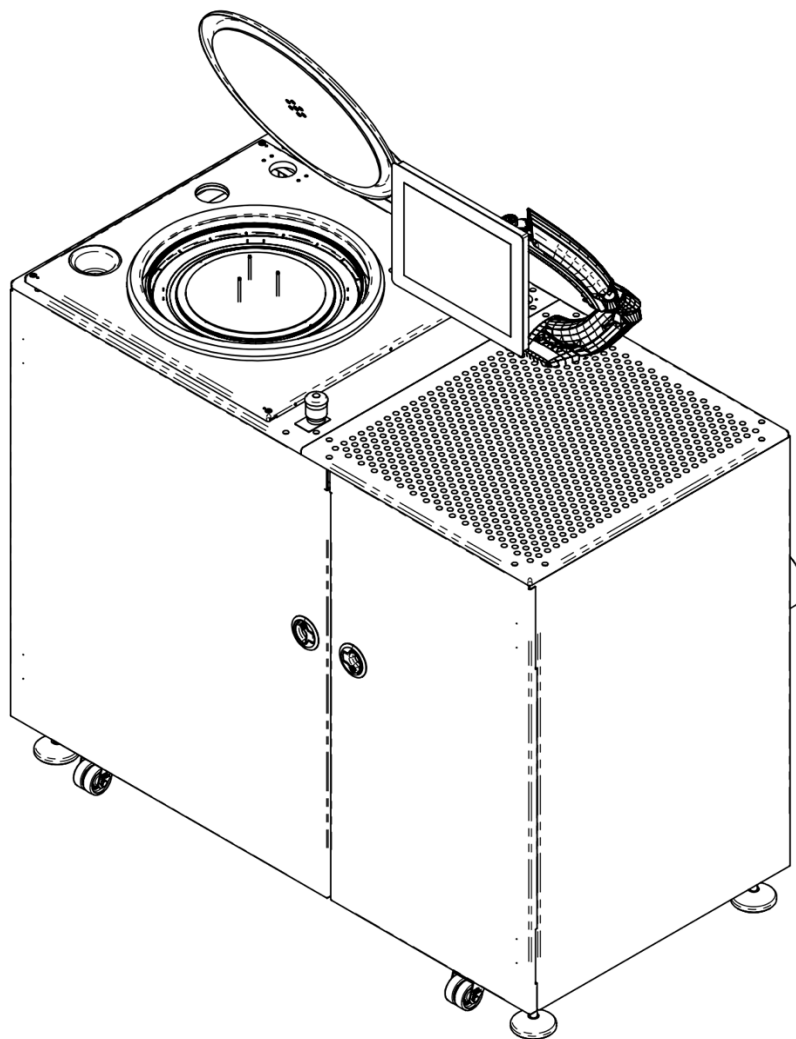

i Important Information

We reserve all rights, including those of reprinting, reproduction or exploitation of the contents of this document or parts thereof. No part may be reproduced in any form, passed on to third parties or duplicated, transmitted or distributed by physical or electronic means without the written permission of Robotechnik Europe GmbH. We reserve the right to update or change content without prior notice.

Robotechnik Europe GmbH strives to continuously improve its products. As a result, there may be differences between the information in this document and the current properties and performance of the products described.

This document has been prepared with the greatest care. Nevertheless, Robotechnik Europe GmbH does not guarantee the accuracy of the content. Claims against Robotechnik Europe GmbH are regulated by the General Terms and Conditions and the licensing provisions of Robotechnik Europe GmbH.

Trademarks and brand names used are registered trademarks of the respective owners.

i Document

Title: OPTIcoat ST30 (PB1025)
 Subtitle: Operating Instructions
 Edition: 11.0
 Date: 2022/03
 Author(s): cch, mba, wda

i Manufacturer

Robotechnik Europe GmbH
 Laubwaldstrasse 15
 78224 Singen
 Germany
 Tel.: +49 (0) 7731 939 894 0
 Fax: +49 (0) 7731 939 820 19
 E-mail: info@robo-technik.eu
 Internet: <http://www.robo-technik.eu/>
 Managing Director: Michael Hitzker

1. Index
2. General Information
3. Safety Instructions
4. Standards, CE Conformity
5. Transportation and Storage
6. Installation
7. Product Description
8. Operation
9. Software
10. Cleaning
11. Maintenance
12. Trouble Shooting
13. Disposal
14. Spare Parts List
15. OEM Manuals
16. Appendix A: Facility Requirements List
17. Appendix B: Machine Layout
18. Appendix C: Electronics & Pneumatics Plan

2 General Information

Table of Contents

	Page:
2.1 Safety Instructions	2
2.2 Liability	2
2.3 Edition	2
2.4 Warranty	2
2.5 Service Address	2
2.6 Symbols Used in the Manual	3

2.1 Safety Instructions

All safety instructions will be found in chapter 3 and following ones.

Prior to installation, starting-up and operation of the system relevant safety instructions must be read carefully and considered accordingly.

2.2 Liability

The manufacturer of the system accepts no liability for material damage, personal injury or consequential damage resulting from improper operation and/or failure to observe the safety instructions or from the user manual no longer being up to date in the event of subsequent modification of the system or the application programme by third parties. The manufacturer also accepts no liability for consequential damage caused by loss of data.

Our products are subject to a constant technical change process due to optimisations as well as legal guidelines and standards. As a result, in individual cases there may be differences between the description in this documentation and the actual system delivered. In case of ambiguities or differences, please contact the manufacturer immediately.

Product names mentioned in this manual may be trademarks and are used for identification purposes only.

2.3 Edition

Edition	Year / Month	Name of the Item	Description	Number
11.0	2022 / 02	OPTIcoat ST30	Spin Coating System with "Covered Chuck"	400080

2.4 Warranty

We guarantee for the equipment as stated in the order/contract.

This warranty will expire in case of:

- interference into or modification of the system without prior consent of the manufacturer
- improper use of the system
- insufficient maintenance of the system
- inappropriate operation of the system
- negligence of correct supply requirements
- application of third-part components
- alteration of program or configuration write-ups without manufacturer's consent

2.5 Service Address

Robotechnik Europe GmbH
 Laubwaldstrasse 15 | 78224 Singen | Germany
 Tel.: (+49) (0) 7731 939 894 0
 Fax: (+49) (0) 7731 939 820 19
 E-Mail: info@robo-technik.eu

2.6 Symbols Used in the Manual



Condition

Defined conditions must be met in order to execute next action.



Action

You are requested to do something.



Result

Explains the result of an action.



Help

Actions to make, should problems occur



Decision

Description of alternative actions.



Information and additional advice



Text or key / button



Checkbox (option present, if checked)

3 Safety Instructions

Table of Contents

	Page:
3.1 General.....	2
3.2 General Hazards.....	3
3.3 Maintenance	4
3.4 Mechanical.....	4
3.5 Spinning Operation.....	5
3.6 Power Supply	6
3.7 Additional Safety Information	8
3.8 Safety Cover Concept.....	9
3.9 Handling of Electronic Components	10
3.10 Chemicals	11
3.11 Media Waste Canister	13
3.12 Symbols Used on System	14
3.13 Emergencies.....	18

3.1 General

Prior to installation, commissioning and operation of the system, the operating instructions and the safety and warning instructions stated therein must be carefully read and observed.

Persons responsible for the transport, storage, commissioning, use, maintenance and repair of the system must be familiar with the contents of the operating instructions.

All instructions must be observed, especially the safety and warning instructions. This will ensure safe operation of the system.

Possible sources of danger that could result in personal injury or damage to the system are also expressly pointed out again in the relevant chapter of the operating instructions. These operating instructions provide important information that is a prerequisite for safe and economical operation of the system.

They must be kept accessible in the immediate vicinity of the system.

In addition to the operating instructions, the generally applicable legal and other regulations for accident prevention and environmental protection in the respective country apply.

Warnings and important notes are presented as follows.



DANGER!

The word "Danger!" combined with this or a more specific symbol indicates an immediate hazard while using the system.

Neglecting of instructions given in this documentation or on the system itself can result in personal injury or death of the operator or of persons being close by.

The system, other equipment or the environment can be seriously damaged as well.



WARNING!

The word "Warning!" combined with this or a more specific symbol indicates an impending hazard or fatal unsafe practice while using the system.

Neglecting of instructions given in this documentation or on the system itself can result in severe personal injury of the operator or of persons being close by.

The system, other equipment or the environment can be damaged as well.



CAUTION!

The word "Caution!" combined with this or a more specific symbol indicates a possible hazard or unsafe practice while using the system.

Neglecting of instructions given in this documentation or on the system itself can result in personal injury of the operator or of persons being close by.

The system, other equipment or the environment can be damaged as well.

Please pay particular attention to the safety instructions, which describe possible hazards when operating the system and how to avoid them.

The safety instructions and warnings described in this chapter do not replace the safety regulations and rules that apply to the individual topics but are special instructions that must be followed in addition to the regulations that must be followed anyway.

3.2 General Hazards

This system has been designed and manufactured considering all relevant safety regulations. Improper use or operation by persons not qualified accordingly may result in danger:

- to life and health of the operator
- to the system itself
- to surroundings of the user
- to performance and efficiency of the system.

General hazards of the system, depending on design or type, may arise in the following ways:

- mechanical hazard caused by squeezing, shearing and cutting, catching and winding, stitching or by freely moving parts
- thrust caused by kinetic energy of moving mass
- sharp corners and edges
- electrical hazard caused by touching live parts (directly or indirectly)
- thermal hazard causing burns
- chemical hazard causing poisoning, corrosion and explosion
- toxic hazard due to inhalation of vapours and gases
- gases under pressure
- liquids under pressure
- combination of hazards caused by
 - faulty installation
 - incorrect loading of substrates / wafers
 - malfunction of power or media supply
 - malfunction of the extraction system or the required air flow
 - failure and/or incorrect arrangement of preventive measures
- combination of escaping media
- hazards caused by
 - human misconduct
 - noise
 - allergies, excitations of mucous membrane, unknown effects caused by media
 - ejection of parts
 - disturbance / malfunction of control system
 - leaking of hoses or pipes
 - combination of atmospheres or vapours
 - fire hazard
 - natural hazards caused by lightning, environmental catastrophes etc.

3.3 Maintenance



DANGER!

Never clean an installed chuck with solvent, as the solvent could destroy the motor.

3.4 Mechanical



DANGER!

By applying components of other manufacturers additional and unknown hazards may arise. No liability will be taken in this case.
Use only genuine parts provided by the manufacturer of the system.
Genuine parts are constructed conforming to applicable safety regulations.



DANGER!

Moving parts may cause squeezing or cutting of extremities.
Do not touch any moving parts of the system while in operation.



DANGER!

Operation of the system by several persons may cause hazards based on misconduct or missing mutual understanding.
Operation of the system by two or more persons is therefore not permitted.
If in case of service or maintenance tasks the system has to be operated by two persons, these have to conduct a secure joint procedure.



DANGER!

The system may only be operated while the safety cover / enclosure is closed, and any protection systems are properly positioned. Function of safety cover has to be assured at any time.
In case of any safety deficiencies the system has to be switched off and the service personnel has to be informed accordingly.



DANGER!

Removing safety covers or doors (except for service purposes) is prohibited. The system must never be opened while the process is running or with the mains cable connected.

3.5 Spinning Operation



DANGER!

Ejection of parts (only with low-contact spin chuck)

When using a spin chuck without vacuum, the rotation speed may not exceed 2000 rpm.



DANGER!

Pollution of the spinning module

The spinning module has always to be operated with chuck and wafer / substrate, except when using a low contact chuck.

Without substrate, the medium can get into the vacuum system.

Without chuck, the medium can also get into the interior of the system.

3.6 Power Supply



DANGER!

Electrical hazard

Disconnect the mains plug before opening the control panel.



DANGER!

Electrical hazard

Solvents and process chemicals can be ignited by electric fields or by electrostatic charging of metal and plastic components and lines.

The system must always be grounded during operation. Never disconnect or remove the protective grounding wires in the system or the mains supply line.



DANGER!

Electrical hazard

This system operates under high voltages. Danger of high voltages exists even when the system is switched off, but still connected to the power supply.

Capacitors within the system may be charged even in case the system is switched off and disconnected from mains supply line.



DANGER!

Electrical hazard

While switched on, electrical connectors will be live. Opening of covers or removing of parts may result in exposure to live parts.



DANGER!

Electrical hazard

Interchange of current-bearing wires may result in danger for health and life of operator. Connection to the mains supply must be affected by a qualified electrician according to prevailing regulations. Neutral wire (blue) and ground wire (green/yellow) must be connected in due form.



DANGER!

Electrical hazard

Persons bearing a pacemaker may not operate, clean or service the unit.

**DANGER!**

Electrical charging hazard
Due to electrical charging plastic components or wiring, solvents and process chemicals could be ignited. Therefore, the system and its components must be grounded.

**DANGER!**

Danger due to electricity!
Only clean the system when it is de-energised.

**DANGER!**

Danger due to electricity!
Do not use dripping wet cloths or high-pressure cleaners to clean the system.

**DANGER!**

Emergency Stop button
The system must not be operated without an emergency stop button. All systems (insert systems only) without emergency stop button have to be supplied with one. In case of emergency the emergency stop button must be approachable immediately. The maximum distance between emergency stop button and machine is 0.5 m.

3.7 Additional Safety Information

- Do not take actions on the system other than described in this manual.
- Do not operate the system while covers or other protective systems have been removed.
- Maintenance and service work may only be executed by Robotechnik service personnel or persons qualified accordingly.
- Disconnect all wires of power supply prior to opening of the system. In case work has to be done while the system remains open (for adjustments, maintenance etc.) it should only be done by qualified personnel, knowing all potentially dangerous points and being able to prevent hazards by taking appropriate precautions.
- In case fuses have to be replaced make sure that only fuses of same type and current rating will be used.



DANGER!
Under no circumstances use makeshift fuses or short-circuit any fuse holders.

- In case of insufficient grounding or of damaged ground conductor make sure that the system will be inoperable and secure it against unauthorized or unintentional operation.
- Whenever it is likely that the system is no longer electrically safe, make it inoperable and secure it against any unauthorized or unintentional operation.
- The system is likely to be electrically unsafe if:
 - a) any damage is visible
 - b) it fails to perform according to specification
 - c) it has been subject to prolonged storage under unfavourable conditions or has been out of service
 - d) it has been subject to severe transport stress.

In these cases the safety state of the machine has to be checked by Robotechnik service personnel.

3.8 Safety Cover Concept

For safety reasons process running is only allowed with closed chuck cover.

The cover of the Covered Chuck system serves not only as a process cover but also as a safety cover to prevent operators from getting in contact with the turning chuck during a coating process. The force and movement of cover is limited/reduced. Only when the cover is closed and the motor starts to turn, it will be pushed down with extra force so it's locked in position. In case of an emergency stop, the chuck cover will stay in its position.

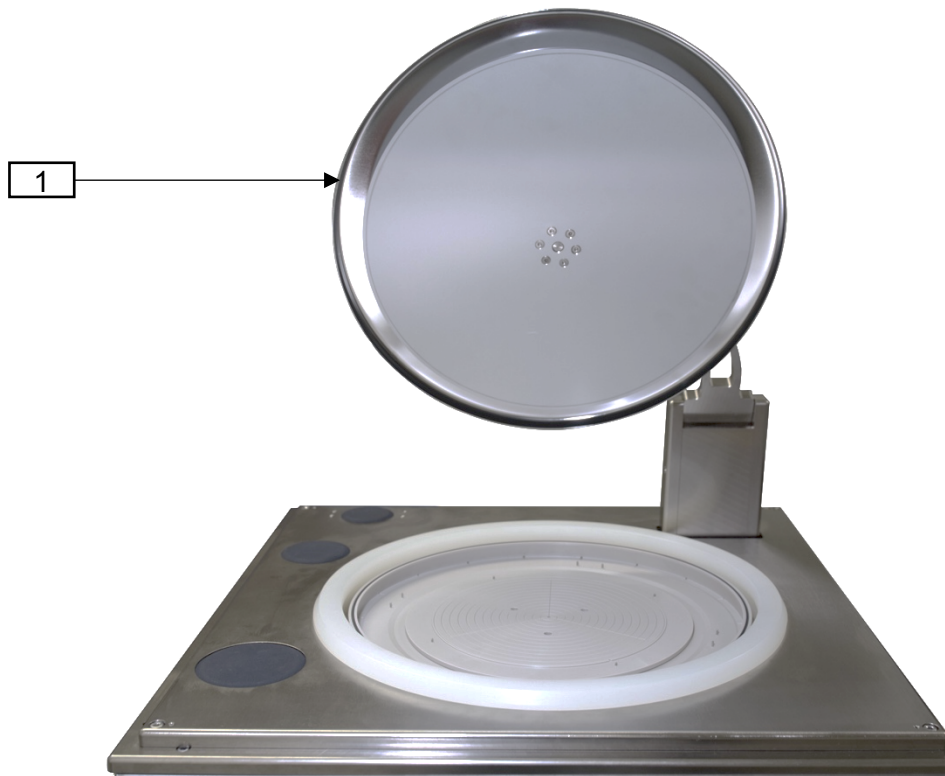

1. Cover of Covered chuck

The force and movement of the closing and opening cover is limited by reducing the used air pressure. The pressure regulator is installed for this purpose and the set air pressure must be checked at regular intervals. The maximum allowed pressure is 2.5 bar.

3.9 Handling of Electronic Components

Electrostatic discharges can cause damage to parts.

For handling electronic components several precautions are essential:

- Wear a grounded wrist strap or work on a grounded static-dissipating work surface. If this not possible touch an adjacent earth ground (i. e. central heaters or water pipes) before handling electronic components or printed circuit boards.
- Leave electronic components and printed circuit boards in their original packaging until final installation.
- Handle electronic components by their body or case, avoid touching of leads.
- Keep electronic components and printed circuit boards away from such static-generating materials as vinyl's, plastic bags, etc.

Maintenance and repair work required, but not listed in this manual, should only be done by Robotechnik service or by persons of equivalent qualification.

3.10 Chemicals

Chemicals are provided and applied by the user. Proper handling of chemicals is the user's responsibility.

To prevent the formation of a potentially explosive atmosphere inside the system, it may only be installed in rooms that provide sufficient air flow to the interior of the system.

Connect all 3 connection points for ventilation to the same ventilation system. The system only monitors the ventilation at one connection point.

	DANGER! It is the user's responsibility to mark all containers and supply lines of chemicals (e.g., containers of media and waste) with appropriate labels and warning signs.
	DANGER! When handling chemicals, please observe relevant safety regulations as well as supplier's information (safety data sheet and additional advice).
	DANGER! When handling chemicals, insure proper ventilation and exhaust of vapours.
	DANGER! When handling chemicals, please observe that released chemicals may react with each another, leading to unwanted and unknown substances. These substances may bear major additional risks.
	DANGER! Solvents! Inflammable, explosive, toxic - Do not inhale its vapours (danger of suffocation). - Prevent electrostatic loading. - Keep away from ignition sources. - Do not smoke. - Do not eat (danger of poisoning). - Do not touch.

**DANGER!**

Process chemicals!

Inflammable, explosive, toxic

- Do not inhale its vapours (danger of suffocation).
- Prevent electrostatic loading.
- Beware of ignition sources.
- Do not smoke.
- Do not eat (danger of poisoning).
- Do not touch.

**DANGER!**

Corrosives

Inflammable, explosive, toxic

- Do not inhale its vapours (danger of suffocation).
- Prevent electrostatic charging.
- Beware of ignition sources.
- Do not smoke.
- Do not eat (danger of poisoning).
- Avoid contact to eyes.
- Do not touch.

**DANGER!**

Gases

Inflammable, explosive, toxic

- Do not inhale (danger of suffocation).
- Prevent electrostatic charging.
- Beware of ignition sources.
- Do not smoke.

**DANGER!**

In case corrosive, gassing or noxious wet media are applied you have to prevent any peril to your staff by all means.

3.11 Media Waste Canister



DANGER!

Fill-Warning

- Never transport the container when full
First pump out to the minimum filling or even better empty the complete container
- Empty container slowly
Avoid splashing or spilling of the media
- Do not overfill the container.



DANGER!

Only change/empty the media waste tank/canister when the system is stopped, otherwise there is a risk of being squeezed by moving parts (e.g., air cylinders).

The media waste canister may only be changed or emptied when the system is stopped. If the tank is removed for emptying or changing while the system is running, there is a risk of injury from moving parts (e.g., air cylinders) in the system.

The media waste canister is equipped with a fill level sensor which is connected to the machine PLC. When the canister is full, DelfinNet software will give a warning message.

3.12 Symbols Used on System

i The following safety instructions (caution and command symbols) may be seen on the system:

SYMBOLS, US standards

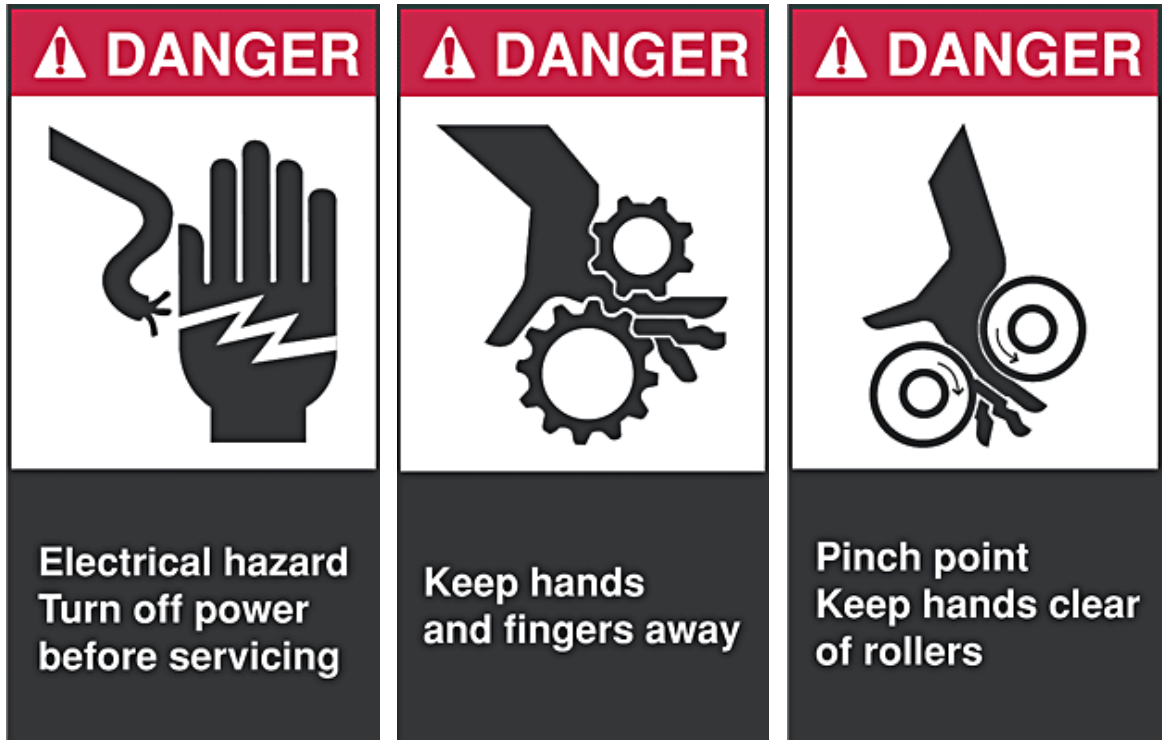

<p>⚠ DANGER</p>  <p>Keep guards in place</p>	<p>⚠ DANGER</p>  <p>Flammable No matches or open lights</p>	<p>⚠ DANGER</p>  <p>Pinch point Watch your hands</p>
<p>⚠ CAUTION</p>  <p>Eye protection required</p>	<p>⚠ CAUTION</p>  <p>Wear gloves in this area</p>	<p>⚠ CAUTION</p>  <p>Hot surface Do not touch</p>

CAUTION SYMBOLS



Warning
General hazard



Electrical hazard



Flammable material
Fire hazard



Toxic Material
Poison



Explosive material
Explosion hazard



Squeezing hazard
Hand crush



Magnetic field



Pinch point
Hand in rollers



Harmful to health



Hot surface



Laser hazard



Automatic start-up

COMMAND SYMBOLS



Read the instructions
manual first



Wear protective gloves



Eye Protection
Wear safety goggles

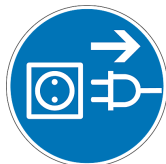

unplug BEFORE open



Respiratory protection
Wear gas mask



Wear protective clothing



Wear conductive boots



Spinning direction clockwise



Spinning direction
anticlockwise

PROHIBITION SYMBOLS

No pacemakers



Do not touch



Keep off area



Do not operate
by several persons



Energized enclosure
No touching - high voltage



Do not extinguish fire by
water



Do not cover



Do not fold up
Prohibition



Do not switch

The above symbols refer to Robotechnik components and parts. However, components and parts of sub suppliers may show other symbols, not expressly mentioned or referred to in this manual.



DANGER!

The owner of the system is responsible to place adequate danger signals and labels in suitable places.

This applies in particular to signals and labels concerning process chemicals used.

Irrespective of number of caution symbols and information placed on or around the system all safety instructions of this manual have to be observed.

3.13 Emergencies

In case of an emergency (accident with material or personal damage), please observe the following instructions:



DANGER!

In case of emergency immediately push the red emergency stop button <EMERGENCY STOP> and await complete stand-still of the system within a safe distance.

Prior to checking of risk area operate the main switch and disconnect the system from the power, nitrogen and (if present) compressed air and, if applicable, media network.



DANGER!

Restarting the system after an emergency stop may only be done by qualified persons. Prior to switching on, check the system for possible danger points and residual hazards.



DANGER!

In case of emergency while handling chemicals (i.e., cleaning or developer media), medical assistance must be provided immediately (doctor/first aid) and the safety data sheet for the chemical used must be followed.

4 Standards, CE Conformity

Table of Contents

	Page:
4.1 Standards Conformity	2
4.2 CE Symbol	2

i This system corresponds in its technical design to various international and national standards, partly not listed here, but including other standards, directions and regulations. The most important ones are listed below.

4.1 Standards Conformity

The system is in conformity with:

- EN 349:1993/A1:2008: safety of machinery - minimum gaps to avoid crushing of parts of the human body
- EN ISO 4414:2010: pneumatic fluid power - general rules and safety requirements for systems and their components
- EN 614-1:2006/A1:2009: safety of machinery - ergonomic design principles
- EN 60204-1:2006: safety of machinery - electrical equipment of machines
- EN ISO 12100:2010: general principles for design - risk assessment and risk reduction
- EN ISO 13849-1:2015: safety of machinery - safety-related parts of control systems - Part 1: general principles for design
- ISO/TS 15066:2017: robots and robotic devices - collaborative robots

4.2 CE Symbol

The system is in conformity with CE requirements and bears the CE symbol. A corresponding manufacturer's statement was forwarded to the user.

CE symbol:



003057

Robotechnik
Europe



EC Declaration of Conformity *EG-Konformitätserklärung*



As defined in the machinery directive 2006/42/EG (Appendix II Part 1 Section A)
Im Sinne der Maschinenrichtlinie 2006/42/EG (Anhang II Teil 1 Abschnitt A)

Manufacturer and contact for the documentation:
Hersteller und Ansprechpartner für die Dokumentation:

Robotechnik Europe GmbH
Laubwaldstrasse 15
D-78224 Singen
Tel: + 49 / 77 31 / 939 894-0
<http://www.robo-technik.eu>

Product description / Produktbezeichnung:

Denomination / Benennung:	Covered Chuck Coater System
Type / Baureihe:	OPTIcoat ST30
Serial Number / Seriennummer:	MB2001
Year of Manufacture / Baujahr:	2022

The products described above in the form as delivered are in conformity with the provisions of the European Directive 2006/42/EG.

Die oben bezeichneten Produkte stimmen in der von uns in Verkehr gebrachten Ausführungen mit den Vorschriften der Europäischen Richtlinie 2006/42/EG überein.

Singen, 08.03.2022

Michael Hitzker

General Manager / Geschäftsführer

5 Transportation and Storage

Table of Contents

	Page:
5.1 Transportation.....	2
5.2 Storage.....	3

**DANGER!**

Prior to installation and operation of the unit, the installation and operating instructions have to be thoroughly read and observed.

5.1 Transportation

**DANGER!**

An overturning unit may cause serious injuries. During transport tipping forces of the unit including its packaging have to be considered.

**DANGER!**

The unit is equipped with transportation castors. If placed on inclining ground, the unit has to be secured against rolling.

**DANGER!**

Upon delivery, moving parts of the system are secured against moving. If the unit is to be relocated later on, all moving parts have to be fixed.

**DANGER!**

Depending on the system and installation site, a forklift truck, lift truck or crane must be used for transport. The minimum lifting capacity of the lifting device must be considered. The weight of the packaging must be added to the weight of the system. For safety reasons, the minimum lifting capacity of the lifting device must be twice the weight of the system.

5.2 Storage

i The system can be stored safely under following conditions:



- without any liquids (process chemicals etc.)
- ambient temperature - 10°C to + 60°C
- ambient relative humidity max. 80%, no condensation
- dust-free and protected (eventually packed up)

When removing from storage, prior to installation, keep the system for at least one day under approved operating conditions.

6 Installation

Table of Contents

	Page:
6.1 Unpacking.....	2
6.2 Operating Conditions	3
6.3 Place of Installation	3
6.4 Preparing the Installation	4
6.5 Connecting Media Supply and Disposal.....	5
6.6 Connecting Power Supply.....	6

	DANGER! Please read the manual, containing required safety instructions, carefully prior to installation, starting and operation of the unit.
	DANGER! Installation and initiation of the electrical equipment have to be affected by competent and qualified personnel only. All valid national instructions (i.e. VDE) have to be observed. Prior to all works assure the disconnection of all components to be installed of power supply.
	DANGER! Ejection of parts (rotating elements) Chucks designed for vacuum operation may never be run without vacuum. When operating the system without vacuum, special spin chucks (Low Contact) have to be used. The rotation speed of Low Contact spin chucks may not exceed 2000 rpm.

6.1 Unpacking

i This is a highly sensitive electromechanical appliance.
Be careful while unpacking, installing, starting and operating the unit.



Check the contents upon unpacking for damages during transport.



In case of transport damages or damages in transit, please contact the manufacturer immediately.



Verify receipt of all parts based on packing list.





In case of missing parts, please refer to the manufacturer.

6.2 Operating Conditions

This system will operate correctly under following conditions:

- clean rooms, class ≥ 10
- ambient temperature + 10° C to + 30° C
- relative humidity max. 60 %, without condensation









	DANGER! Explosive atmospheres! Do not apply any explosive chemicals. Do not operate the system in explosive atmospheres.
	DANGER! Do not operate without suitable exhaust.

6.3 Place of Installation

The system may only be placed on a stable, flat, vibration-free and safe surface not to be deformed under the weight of the unit and eventual accessories (see the Facility Requirements List).

6.4 Preparing the Installation

Depending on used features and media special preparations are necessary:

-  Detach the transport safety unit
-  Align the system with the fixation feet
-  Make sure that the main voltage is connected
-  Make sure that the compressed air and vacuum is connected
-  Make sure that media tanks/bottles are sufficiently filled
-  Make sure that the media waste containers are installed and not full
-  Make sure that the operation pressure is set on 6 bars
-  Make sure that the exhaust is connected and working

6.5 Connecting Media Supply and Disposal

For detailed information and requirements, please refer to chapter Facility Requirements List, the electrical and pneumatic/vacuum drawings and the customer specific list of connecting values.

All media lines connected with the system's reverse are carrying unmistakable plugs.
The sockets are marked appropriately.



DANGER!

Prior to media connections make sure that the system is disconnected from current.





DANGER!

In case corrosive, gassing or noxious wet media are applied you have to prevent any peril to your staff by all means.

6.6 Connecting Power Supply

i All cables, connected with the system, are carrying unmistakable plugs. The sockets are marked appropriately.

 **DANGER!**
Connect the mains cable at last (after all connections) to the house power supply.

 **DANGER!**
An Emergency Stop button is required. Look for the connection values in chapter Technical Data. Without Emergency Stop button operating the system isn't allowed. The Emergency Stop button with connection is delivered by the manufacturer.

 **DANGER!**
Each installation and operation work at electrical equipment must be done by qualified personnel. The valid national instructions (e.g. VDE) have to be followed. Prior all work check the system's disconnection of the power supply.



Make sure that the main switch is in <0/OFF> position



Connect power cable to power supply system

For detailed information and requirements, please refer to chapter Facility Requirements List, the electrical drawings and the customer specific list of connecting values.

7 Product Description

Table of Contents

	Page:
7.1 Intended Use.....	3
7.2 Total View	4
7.3 Process Area	5
7.4 Process Chamber (media waste and pneumatics area).....	6
7.4.1 Valve Station	7
7.4.2 Chuck Motor with Media Separation	8
7.4.3 Digital Pressure Switch/Sensor for CDA and Vacuum.....	9
7.4.4 Cover Pressure Regulator.....	9
7.4.5 Media Waste Canister	10
7.4.6 System Type Label and Facility Requirements List	11
7.5 Electronics Area.....	12
7.6 Back Side	13
7.6.1 Process Bowl Exhaust with Exhaust Monitor	14
7.6.2 Exhaust Monitor	15
7.6.3 Power and Media Supply Connection Panel	16
7.7 Vacuum Pump	17

Table of Figures

	Page:
Figure 1: Total view	4
Figure 2: Process area	5
Figure 3: Media waste and pneumatics area	6
Figure 4: Salve station.....	7
Figure 5: Valves assignments	7
Figure 6: Chuck motor with inspection glass.....	8
Figure 7: Digital pressure switch/sensor for CDA and Vacuum	9
Figure 8: Cover pressure regulator	9
Figure 9: Media waste canister	10
Figure 10: System type label and facility requirements list	11
Figure 11: Electronic area	12
Figure 12: Back side.....	13
Figure 13: Media exhaust with exhaust monitor.....	14
Figure 14: Exhaust monitor	15
Figure 15: Power and media supply connection panel	16
Figure 16: Vacuum pump	17

7.1 Intended Use

The OPTIcoat ST30 Spin Coating Process System is a state-of-the-art equipment for single wafer / substrate coating process applications. The optimized process bowl with covered chuck technology provides excellent coating results, cleanliness and repeatability for substrates up to 9" x 9" or wafers up to 300mm. Please refer to the agreed specifications for more information.

The stand-alone cabinet of the OPTIcoat ST30 has been specifically designed for easy operation and maintenance. With the wide range of options, the system can also be upgraded for higher automation and improved substrate to substrate process repeatability.

The OPTIcoat ST30 system is specially intended

- for laboratories and research institutions to run test or small series productions
- for small series production in industrial clean rooms



DANGER!

This OPTIcoat ST30 is not suited or designed for any other applications than the ones stated above.

Any other use or structural modification of the system is only permitted after consultation with the manufacturer and by written approval.



DANGER!

Chemicals

Without proper protection the system is not suited for the application of explosive or hazardous chemicals.

Our products are subject to a constant technical change process due to optimisations as well as legal guidelines and standards. As a result, in individual cases there may be differences between the description in this documentation and the actual system delivered. In the event of ambiguities or differences, please contact the manufacturer immediately.

7.2 Total View

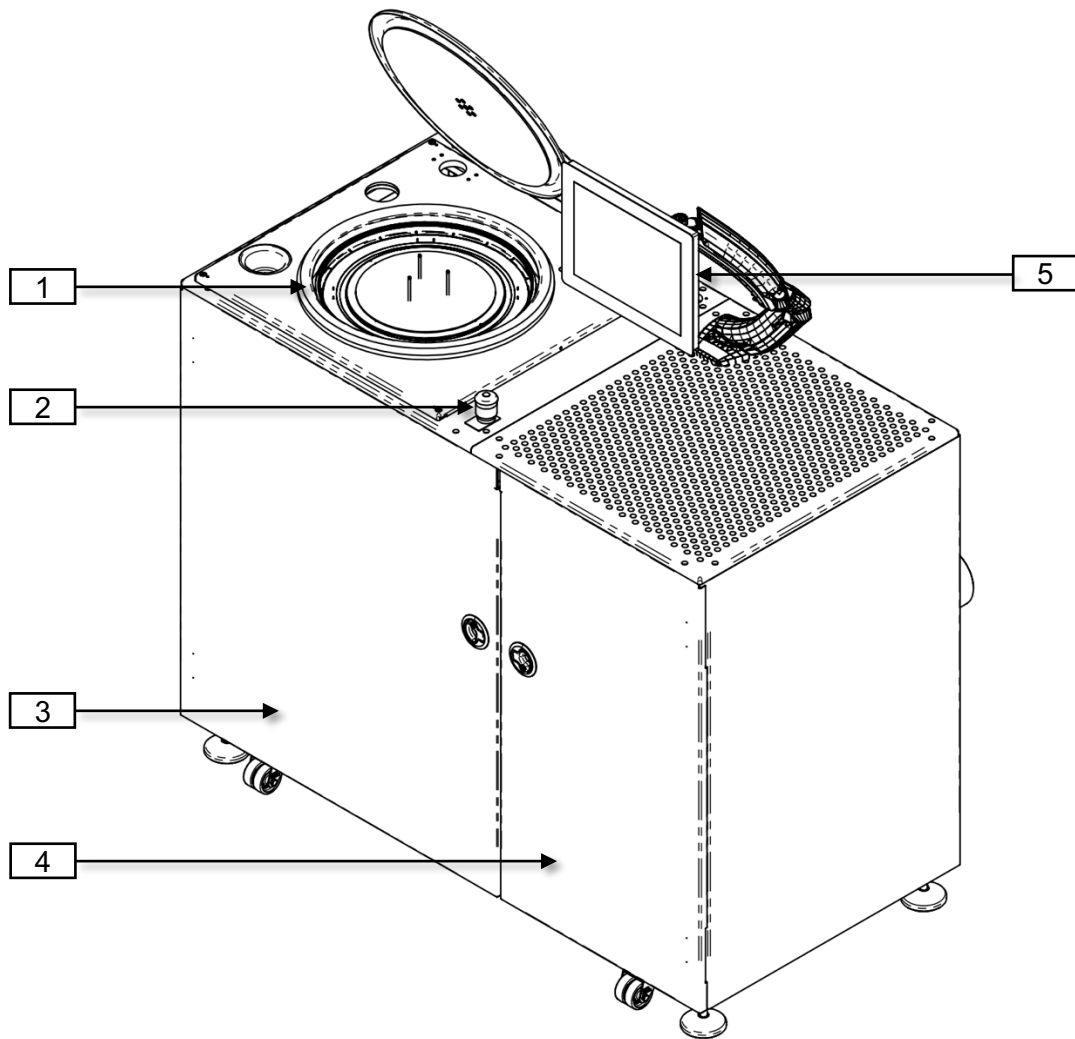

Figure 1: Total view

1. Process area
2. Emergency stop button
3. Media waste and Pneumatics area
4. Electronics area
5. Touch display

7.3 Process Area

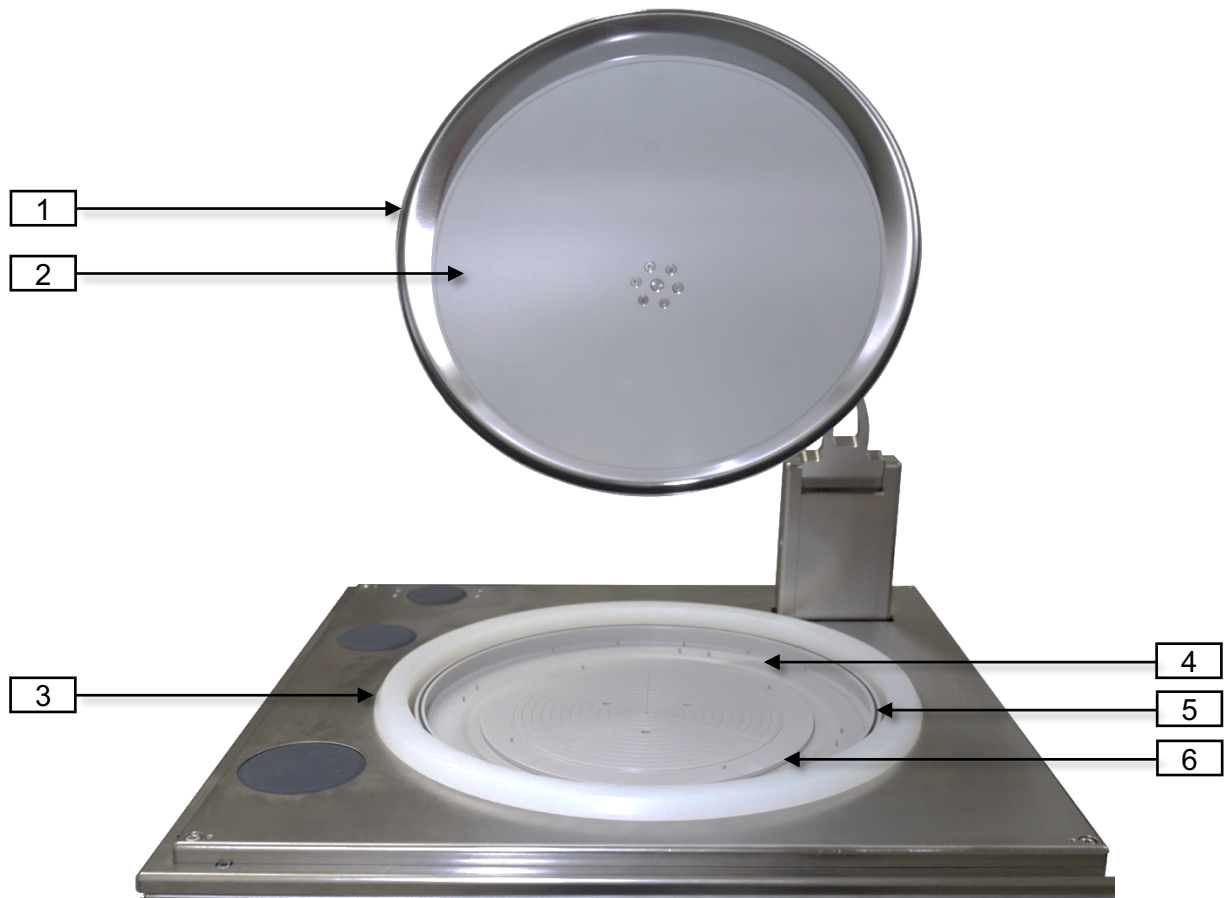

Figure 2: Process area

1. Safety cover
2. Inner process cover
3. Splash ring
4. Base chuck
5. Sealing ring, ensures the inner cover to rotate with base chuck
6. Vacuum Inlay

The components of process area can be disassembled without using any tools. This design reduces the efforts for cleaning and maintenance work.

7.4 Process Chamber (media waste and pneumatics area)

Media connections are made according to the relative labels stick on the media connection plate and media hoses.

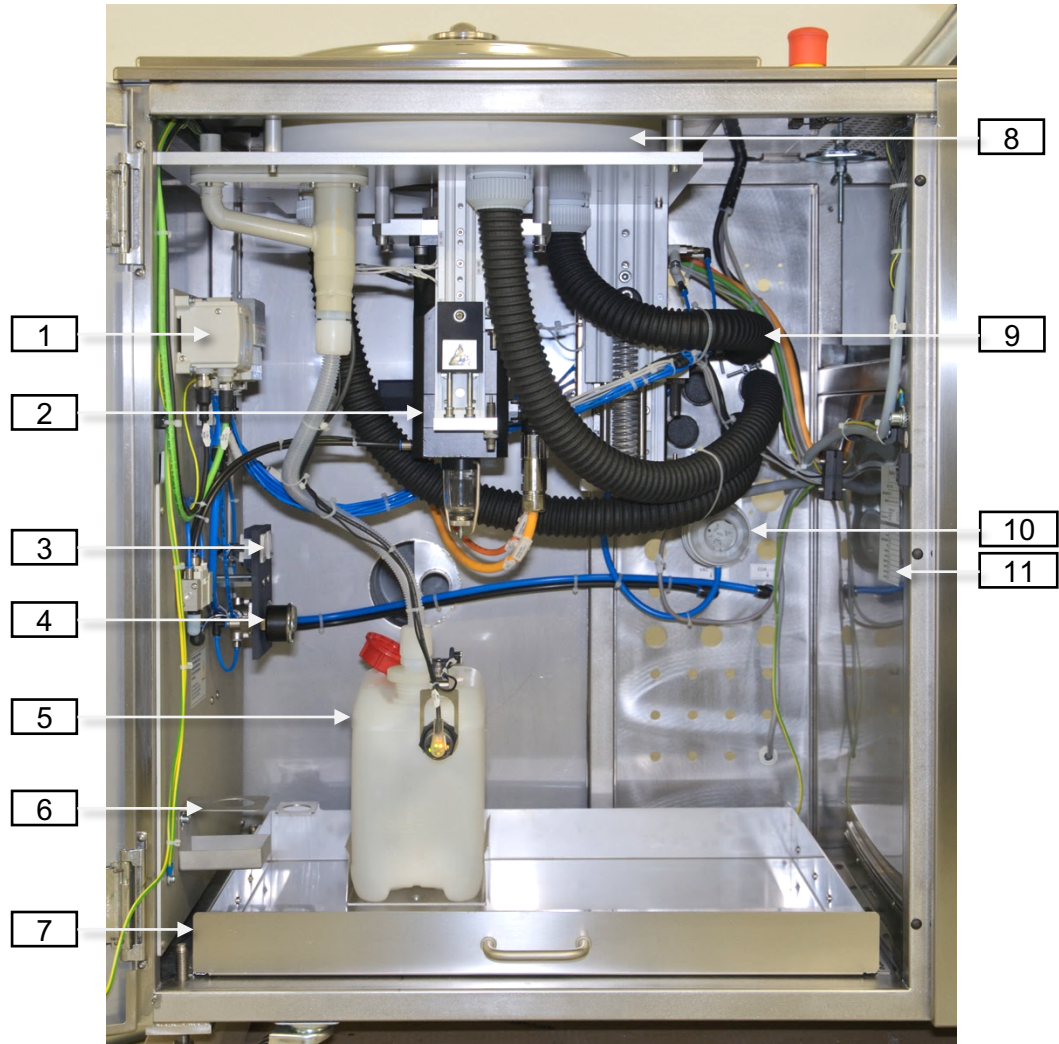

Figure 3: Media waste and pneumatics area

1. Valve station
2. Chuck motor with media collection glass
3. Digital pressure switch/sensor for CDA and vacuum
4. Compressed air regulator for movement of the protective cover
5. Media waste canister
6. Holder for holding the canister lid temporarily
7. Media tray, can be pulled out
8. Process bowl
9. Exhaust tubes of process bowl
10. Exhaust monitor of process bowl
11. System type label and facility requirements list

7.4.1 Valve Station



Figure 4: Valve station

On the inside of the door, an instruction label of the valve assignments can be found.

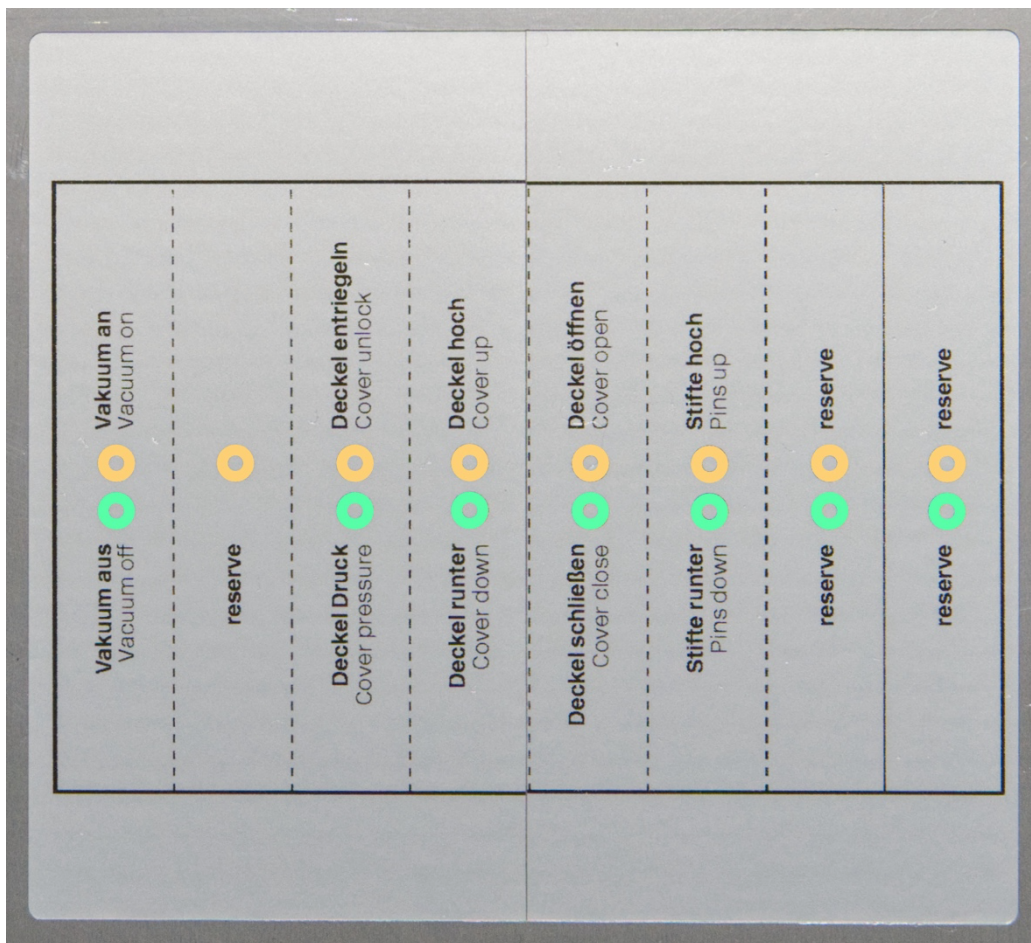

Figure 5: Valves assignments

7.4.2 Chuck Motor with Media Separation

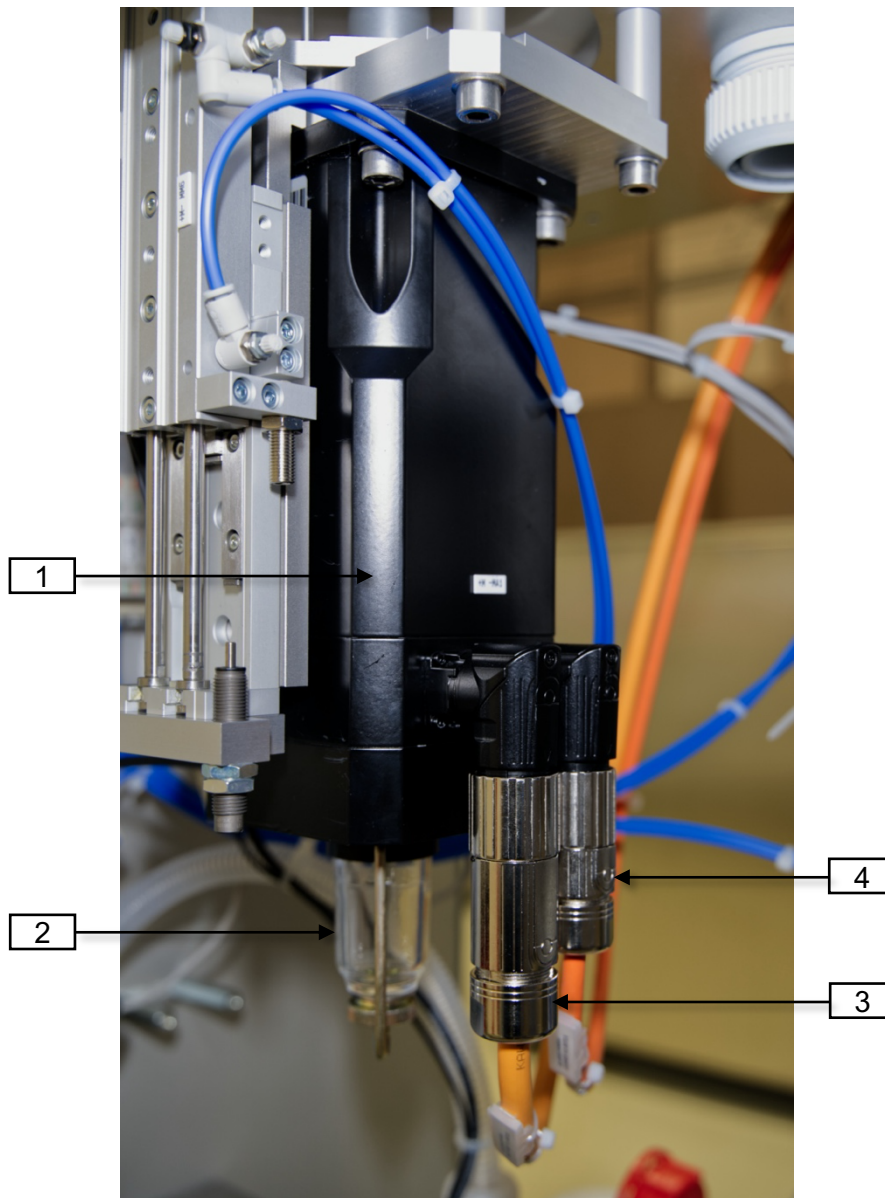

Figure 6: Chuck motor with inspection glass

1. Motor
2. Inspection glass of media separator for vacuum system
3. Motor connection (6-pole circuit socket)
4. Resolver connection (12-pole circuit socket)

The inspection glass of media separator should be regularly checked and cleaned. See chapter 10 Cleaning for more information.

7.4.3 Digital Pressure Switch/Sensor for CDA and Vacuum

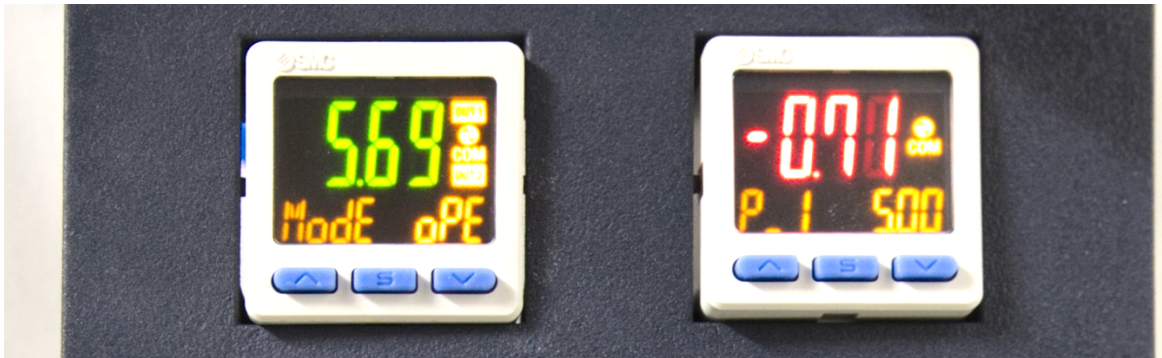

Figure 7: Digital pressure switch/sensor for CDA and Vacuum

Two digital pressure switch/sensors are installed. The one on the left side is used for CDA and the one on the right side is used for Vacuum.

7.4.4 Cover Pressure Regulator



Figure 8: Cover pressure regulator

The force and movement speed of the closing and opening cover is limited by reducing the used air pressure. The pressure regulator is installed for this purpose and the set air pressure must be checked at regular intervals. To read the real pressure value, it is necessary to put the machine in service mode and close the process lid. The maximum allowed pressure is 2.5 bar. Please refer to chapter 3 Safety Instructions for more information.

7.4.5 Media Waste Canister

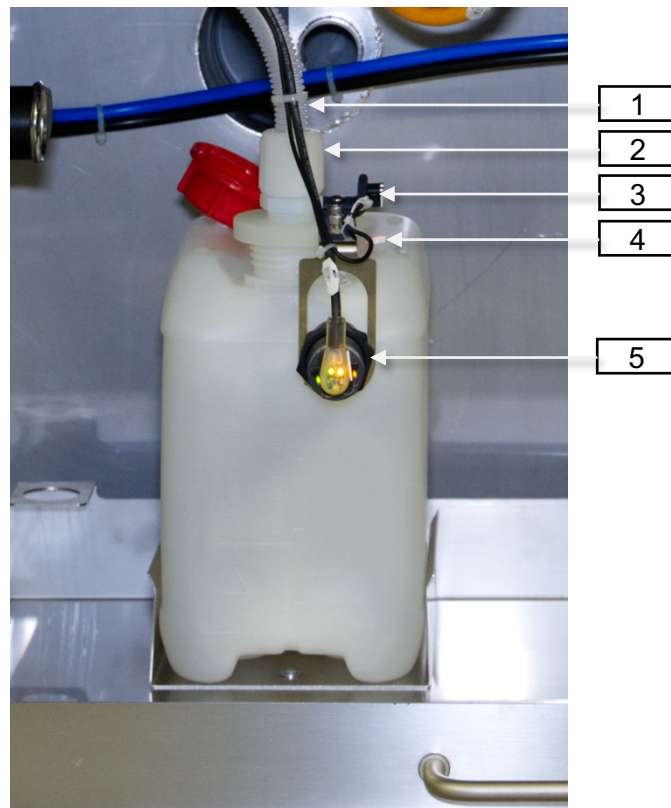

Figure 9: Media waste canister

1. Media waste hose
2. Media waste hose connector
3. Canister presence detection sensor
4. Reflector foil for the sensor stated in Nr. 3
5. Canister fill level sensor

DelfinNet software gives alarms if canister is not present or fill level limit is reached.

7.4.6 System Type Label and Facility Requirements List



		Robotechnik  Europe	
		Type	<i>OPTIcoat ST30</i>
		Serial number S/N	<i>MB2001</i>
		Description	<i>Covered Chuck Coater System</i>
http://www.robo-technik.eu		Robotechnik Europe GmbH Laubwaldstr. 15 78224 Singen Germany	
			
Voltage	<i>400V / N / PE / 50 Hz / 16 A</i>		
Current	<i>16 A</i>		
Power Consumption	<i>1,8 kW/h</i>		
CDA	<i>5,5 bar</i>		
Nitrogen	<i>none</i>		
Vacuum	<i>-0,7 bar</i>		
Noise Level	<i>70db (A)</i>		
Exhaust 1	<i>20 m³/h</i>		
Exhaust 2	<i>80 m³/h</i>		
Exhaust 3	<i>40 m³/h</i>		

Figure 10: System type label and facility requirements list

For more information, please refer to Appendix A: facility requirements list.

7.5 Electronics Area



Figure 11: Electronic area

1. System type label
2. Reset button: button to switch on the actuator voltage
3. Main switch
4. Handle to pull/push the electrical cabinet out/in
5. Transportation lock

The electrical cabinet can be pulled out for service purpose. The transportation lock should be locked during transportation or relocation the machine.

7.6 Back Side

Media connections are made according to the relative labels stick on the reverse side. Maybe they differ from the following figure.

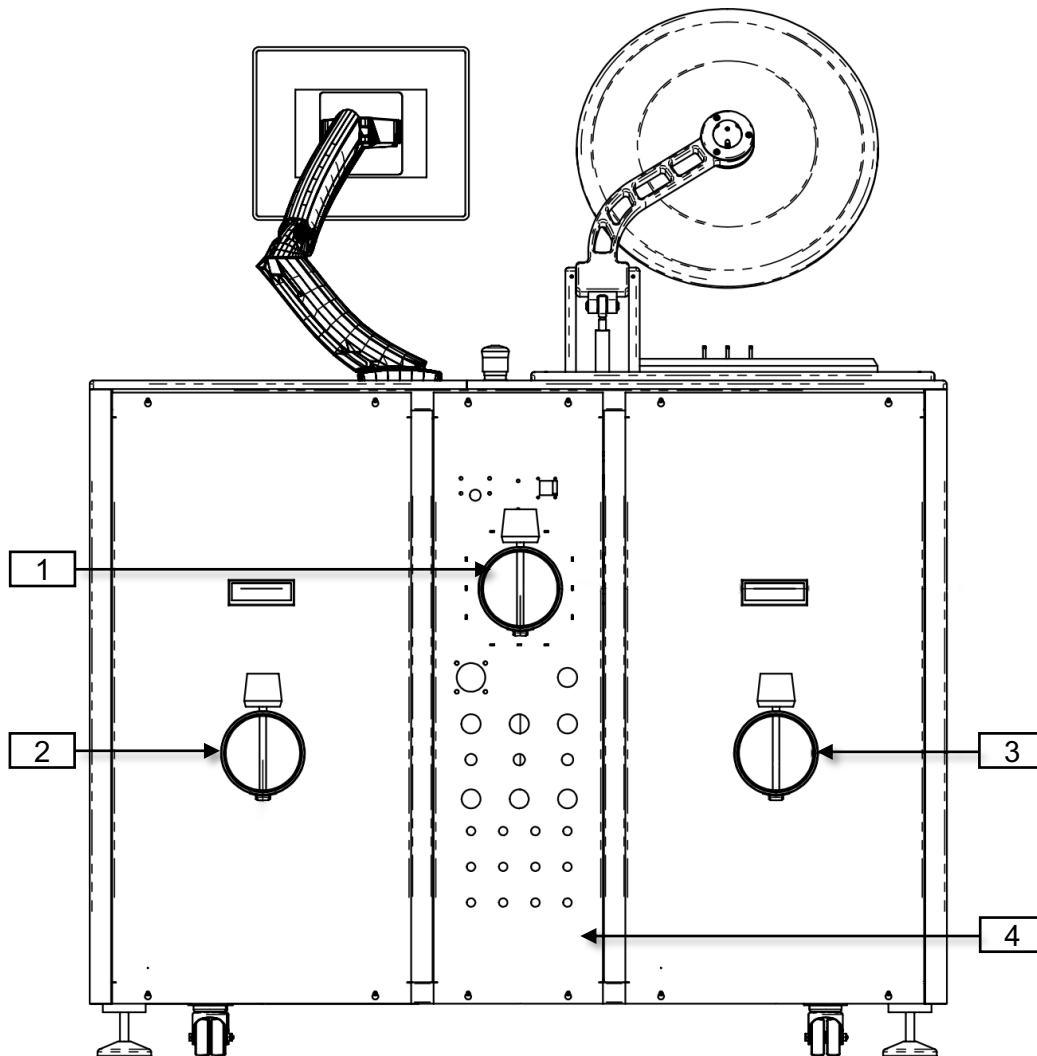

Figure 12: Back side

1. Exhaust for process bowl area with a exhaust detector
2. Exhaust for electronics area
3. Exhaust for process chamber area
4. Power and media supply connection panel

Please run exhaust 30 min prior to operation.

7.6.1 Process Bowl Exhaust with Exhaust Monitor

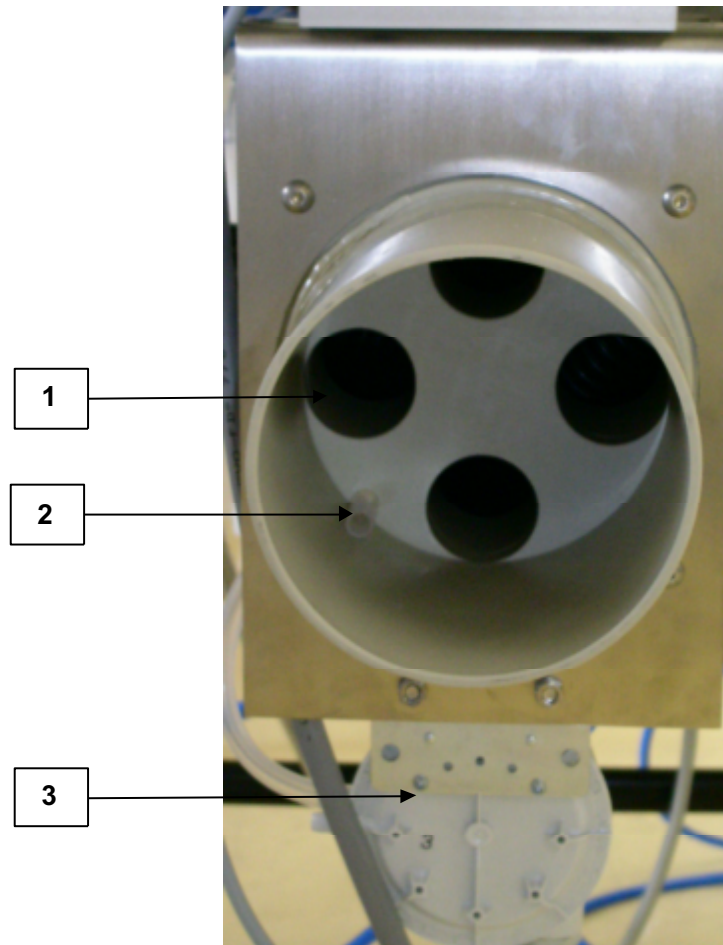

Figure 13: Media exhaust with exhaust monitor

1. Media exhaust
2. Measuring point exhaust monitor
3. Exhaust monitor

7.6.2 Exhaust Monitor

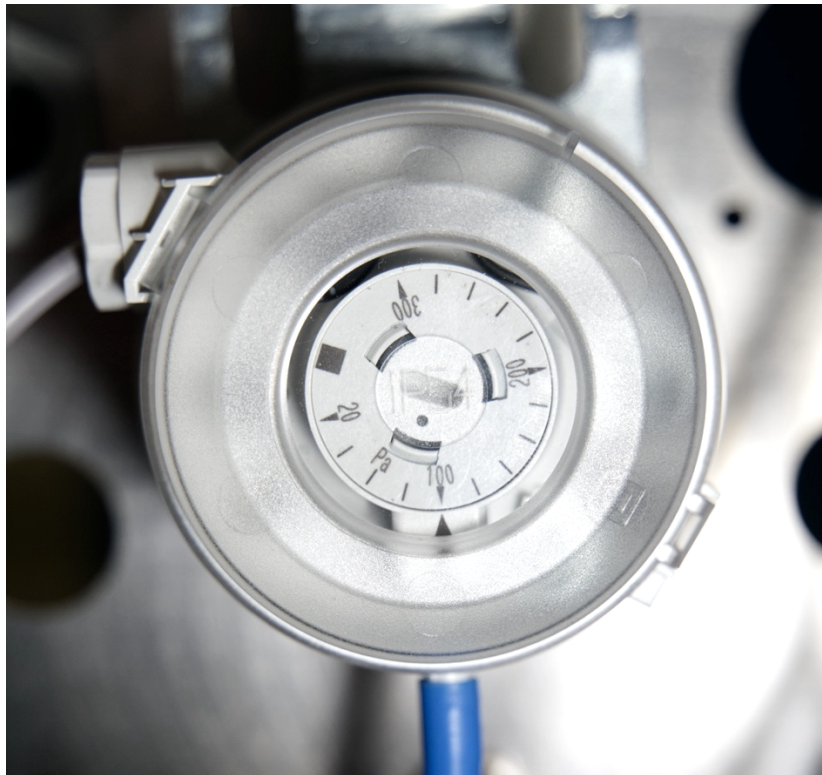

Figure 14: Exhaust monitor

The exhaust monitor (differential pressure monitor) checks if the process bowl connected to an exhaust system. A warning message will be shown on the DelfinNet software if the exhaust is not connected or no pressure difference is detected.

Open the protective cap with a screwdriver and set the vacuum by adjusting the inner disc by hand according to your vacuum.

No further warning message should appear on the DelfinNet software.

7.6.3 Power and Media Supply Connection Panel

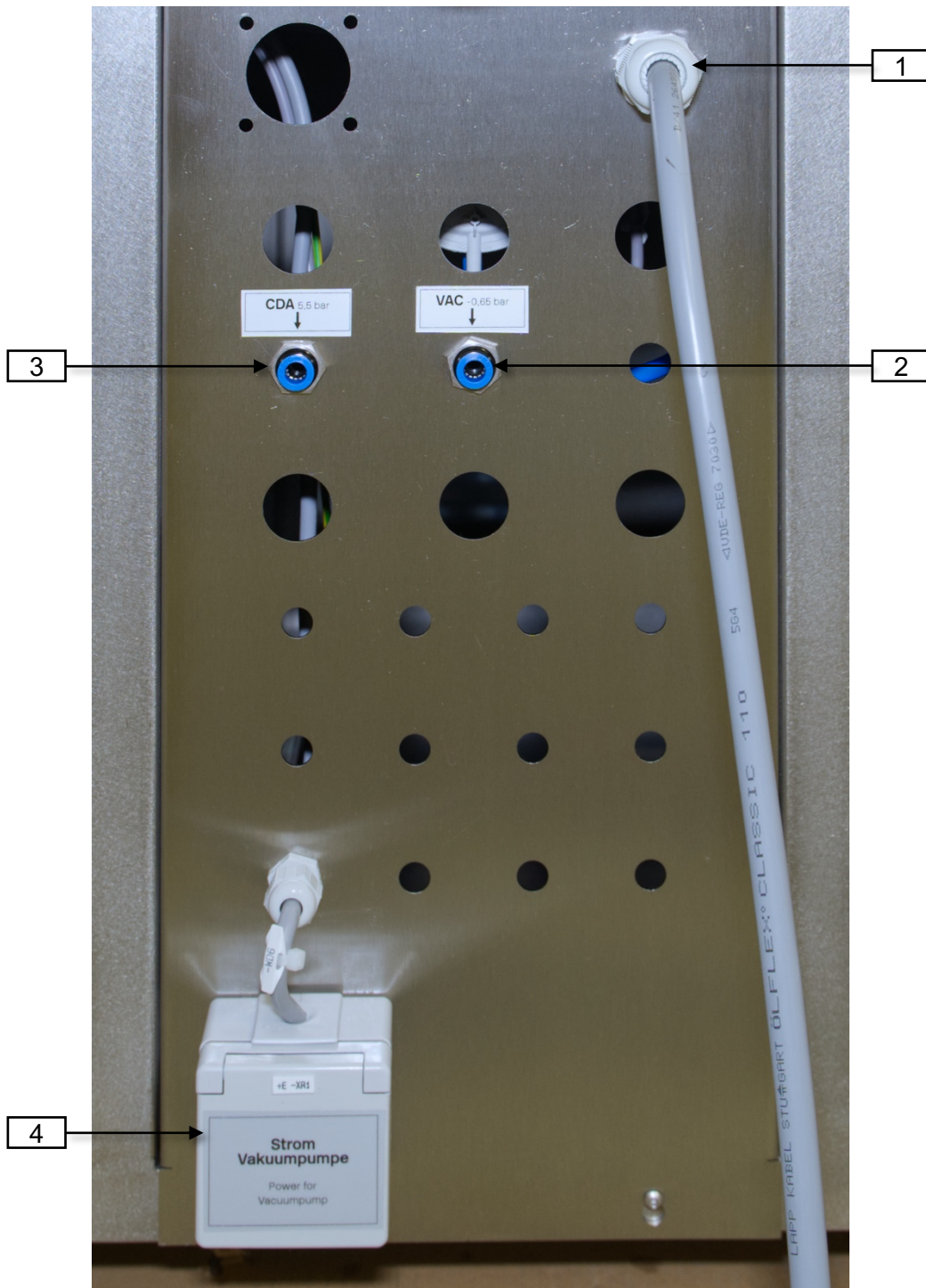

Figure 15: Power and media supply connection panel

1. Main power supply
2. VAC supply, -0.65 bar
3. CAD supply, 5.5 bar
4. Socket for vacuum pump

The media connections correspond to the labels on the back of the unit.

7.7 Vacuum Pump



Figure 16: Vacuum pump

1. Vacuum out connector

The vacuum out connector needs to be connected to the VAC connector on the back side of the machine.
The vacuum pump gets power directly from spin coater by plugging it to the backside of the machine.

Please pay attention to the manufacturer's operating instructions!

8 Operation

Table of Contents

	Page:
8.1 Preparation	3
8.2 Switching On	3
8.3 Switching Off	4
8.4 Stop a recipe in progress	5
8.5 Aborting in Case of Emergency.....	5
8.6 Process Flow	6

**DANGER!**

Depending on form and size of substrates, special spin chucks and inlays are used. Use only a spin chuck suited for the actual substrate.

**DANGER!**

Make sure that the substrate is placed correctly between the centering pins.

**DANGER!**

The system may never be operated without exhaust. Without exhaust, dangerous vapours and fumes can be set free damaging health or parts of system.

**DANGER!**

The system may never be switched on nor operated without vacuum and compressed air.

**DANGER!**

Never touch a rotating spin chuck in the process chamber.

**WARNING!**

Assure the correct installation of the waste canister at the waste pipe of the process chamber.

**DANGER!**

Ejection of parts (Low Contact Chuck)!
When using a Low Contact Chuck without vacuum, the rotation speed may not exceed 2000 rpm.





**DANGER!**

In case of interruption of the spin process dangerous media residues can still be present on the substrate and in the system.
Please make sure to carefully rinse the process chamber and the substrate before removing the substrate.

i If additional/optional features are applied, the actual process may differ from the given description.

8.1 Preparation



Depending on features used with the system (options) and applied media certain preparations are necessary:







-  Assure that media tanks / bottles are sufficiently filled.
-  Assure that the waste containers or house drain connection are installed and not full.
-  Assure that the inspection glass of the motor at the spinning module is not full.
-  Assure that the exhaust is connected and working.

8.2 Switching On





1. Main switch (red)
2. Reset button (white)

-  Assure that compressed air, vacuum and exhaust are connected and functional.
-  Assure that the exhaust system has been running for 30 minutes before turning on the machine.





-  Turn the main switch (red) on the electronics cabinet to <ON>.
-  Wait about two minutes till the IPC boots up and the software **DelfinNet** (§9 Software) automatically opens.
-  After about another minute the Reset button (Actuator Voltage) starts to flash.
-  If the Reset button does not flash, check if the Emergency Stop is pressed.
-  Press the Reset button to activate the Actuator Voltage. The cover will close slowly and stop in the middle position.
-  The Reset button will be lighted up constantly.



WARNING!
Be aware: the movement of cover during the first initialization procedure will be faster and stronger than in normal operation.

-  Press the <Start> button on the DelfinNet software to initialize the system.
-  After the initialization, the cover is fully open, and the application program is ready for loading a new recipe.

8.3 Switching Off

-  Finish the current recipe.
-  Close the application programs DelfinNet and RecipeNet.
-  Shutdown the MS-Windows operating system.
-  Turn the main switch (red) on the electronic cabinet to <OFF>.

8.4 Stop a recipe in progress



Press the STOP button on the DelfinNet software.



Wait till the cover opens and the pins lift up.

8.5 Aborting in Case of Emergency



Press the red emergency-stop-button <EMERGENCY STOP> on the top plate of the system.



All outputs are switched off.



The chuck slows down to "0" with a slight breaking ramp.



The cover will be kept in position.



DANGER!

In case of interruption of the spin process dangerous media residues can still be present on the substrate and in the system.



After each abort and recipe stop the system must be initialized again.

8.6 Process Flow

Following steps make up the process:

1. Program recipes in **RecipeNet** software (see §9 Software)
2. Download a recipe
3. Put the wafer / substrate on the required chuck
4. Switch on the vacuum
5. Dispense the photo resist manually
6. Start the recipe
7. Wait till the recipe is finished and the safety cover is open
8. Take out the processed wafer / substrate
9. Move the pins down

i The cover of the Covered Chuck system acts not only as a process cover but also as a safety cover to prevent the operator from getting in contact with the turning chuck during a coating process. The chuck cover is limited by its force and by its speed. When the cover is closed and the motor starts to turn, it will be pushed down with extra force and locked in position.

i After the application of the resist the surplus resist is slung away by the rotation of the spin chuck, leading to a very thin coat of photo resist. The Covered Chuck Technology (optional) assures that the coat will be even, especially on the corners and edges of rectangular substrates.

9 Software

Table of Contents

	Page:
9.1	Conditions 5
9.2	Install the Programs “RecipeNet” and “DelfinNet” 5
9.3	Update the Programs “RecipeNet” and “DelfinNet” 5
9.4	Update the PLC Program..... 6
9.5	Basic Functions of Operating Robotechnik Software 6
9.5.1	Virtual Keyboard 6
9.5.2	Main Input Fields in Robotechnik Software 7
9.6	RecipeNet..... 8
9.6.1	Toolbar 9
9.6.2	Recipe View - Operating Interface 10
9.6.2.1	<i>Function Field..... 11</i>
9.6.2.2	<i>Recipe View (tab)..... 12</i>
9.6.2.3	<i>Functions of the Menu “General” 13</i>
9.6.2.4	<i>Functions of the Menu “Step” 14</i>
9.6.3	Recipe View - Using the Recipe Editor 16
9.6.3.1	<i>Loading Station Recipes 16</i>
9.6.3.2	<i>Create a New Recipe 17</i>
9.6.3.3	<i>Delete a Recipe..... 18</i>
9.6.3.4	<i>Modify a Recipe 18</i>
9.6.3.5	<i>Insert, Add, Move, Delete a Recipe Step 19</i>
9.6.3.6	<i>Save a Recipe 20</i>
9.6.4	Terminal 21
9.6.4.1	<i>Schedule - TERMINAL..... 22</i>
9.6.5	Configuration 22
9.6.5.1	<i>Schedule - CONFIGURATION..... 23</i>
9.6.5.2	<i>Schedule - Simulation 23</i>
9.6.6	Information Window 24
9.6.7	Open Virtual Keyboard 25
9.6.8	Exit RecipeNet..... 25
9.7	DelfinNet 26
9.7.1	Toolbar 27
9.7.2	Initialisation of the System 29
9.7.2.1	<i>Function Sequence 29</i>
9.7.2.2	<i>Function - Initialization after Abort..... 30</i>
9.7.2.3	<i>Function – Initialization succeeded 31</i>
9.7.3	Basic Functions and Parameters 32
9.7.4	Configuration 33

9.7.4.1 Function Sequence – System Configuration File	34
9.7.4.2 Password	35
9.7.5 Service Functions	37
9.7.5.1 Service window start	38
9.7.5.2 Service Tab - Function	39
9.7.5.3 Service Tab - Terminal.....	40
9.7.5.4 Service Tab - Handling.....	41
9.7.5.5 Service Tab - Media.....	42
9.7.5.6 Service Tab - Analog Values.....	43
9.7.5.7 Service exit.....	44
9.7.6 Open Virtual Keyboard	45
9.7.7 Horn.....	45
9.7.7.1 Function sequence.....	45
9.7.8 Information Window	46
9.7.8.1 Open the Operating Instructions	47
9.7.8.2 Terminal	47
9.7.8.3 Password	48
9.7.9 Exit DelfinNet.....	49

Table of Figures

	Page:
Figure 1: Virtual keyboard (example)	6
Figure 2: RecipeNet - start window	8
Figure 3: RecipeNet - toolbar	9
Figure 4: RecipeNet - operating interface	10
Figure 5: RecipeNet - function field recipe editor	11
Figure 6: RecipeNet - recipe tab	12
Figure 7: RecipeNet - recipe view "General"	13
Figure 8: RecipeNet - recipe view "Step"	14
Figure 9: RecipeNet - select station	16
Figure 10: RecipeNet - system, delete recipe	18
Figure 11: RecipeNet - system, delete step	19
Figure 12: RecipeNet - terminal	21
Figure 13: RecipeNet - configuration dialog	22
Figure 14: RecipeNet - configuration, for example, open a configuration file	23
Figure 15: RecipeNet - information window (example)	24
Figure 16: RecipeNet - exit application	25
Figure 17: DelfinNet - start window	27
Figure 18: DelfinNet - upper toolbar	27
Figure 19: DelfinNet - start init.....	29
Figure 20: DelfinNet - System abort.....	30
Figure 21: DelfinNet - Initialize System	30
Figure 22: DelfinNet - Initialization succeeded	31
Figure 23: DelfinNet - station, tab "info"	32
Figure 24: DelfinNet - configuration dialog	33
Figure 25: DelfinNet - configuration file	34
Figure 26: DelfinNet - enter password.....	35
Figure 27: DelfinNet - set password	36
Figure 28: DelfinNet - enter password.....	38
Figure 29: DelfinNet - service tab Function	39
Figure 30: DelfinNet - service tab Terminal.....	40
Figure 31: DelfinNet - service tab Handling.....	41
Figure 32: DelfinNet - service tab Media	42
Figure 33: DelfinNet - service tab Analog.....	43
Figure 34: DelfinNet - information window (example)	46
Figure 35: DelfinNet - terminal window	48
Figure 36: DelfinNet - exit.....	49

i Two kinds of application programs are used to program and operate the system manually and automatically. Different functions are integrated in various modules.

- Recipe administration (Program “RecipeNet.exe”)
 - Create recipes for all stations
 - Create process flows
- Process administration (Program “DelfinNet.exe”)
 - Start, stop of automatic processes
 - Service and configuration

i The system’s touch screen monitor is used for operating the application programs. The onscreen keyboard can be activated directly via DelfinNet software.



DANGER!

Electricity

The controller, the PC and all electrical connections are inside the system. Because of safety each modification and usage of additional connections has to be permitted by the manufacturer. Without written permission the manufacturer will not take any liability of damage and reserves the right to reject any guarantee demands.



CAUTION!

Data consistence and continuity

Pay attention to the correct input and order of commands and characters when editing configuration and recipe files (.config and .xml files) with the text editor.

Incorrect input can cause an abort or a wrong action of the system.

Configuration files may only be modified by the manufacturer or with written permission of the manufacturer. Without written permission the manufacturer will not take any liability of damage and reserves the right to reject any guarantee demands.



CAUTION!

Loss of data

The manufacturer assumes no liability in case of data lost.

The manufacturer recommends backing up the config file and the recipes to an external drive.

Please note chapter “RecipeNet / DelfinNet - Configuration”

9.1 Conditions



Following requirements should be met for installation and application of the recipe editor (file "RecipeNet.exe") and the application program (file "DelfinNet.exe")

- an operating system Windows 10 from Microsoft is installed
- a user profile is installed in the operating system
- DotNet-Framework from Microsoft, Version 4.5 or higher is installed



DotNet-Frameworks 4.5 is on the Windows Installation CD or can be downloaded in the actual version to the operating system from the Microsoft website. For installation administrator rights for MS-Windows are required. More detailed information is displayed when installing the file "Dotnetfx.exe".

9.2 Install the Programs "RecipeNet" and "DelfinNet"

Following steps must be done when installing the OPTIcoat software



Create a path on the drive C:\ with the name "RTEU"



Copy the complete contents of the folder "RTEU" from the external drive to "C:\RTEU"



Create a link on the desktop to the file "RecipeNet.exe" in the path "C:\RTEU \RecipeNet"



Create a link on the desktop to the file "DelfinNet.exe" in the path "C:\RTEU \DelfinNet"



A path differing from "C:\RTEU" is possible. You modify each path declaration in the configuration windows of RecipeNet and DelfinNet (see chapter "Configuration"). If path declarations are missing a configuration window with the input command opens at the start of RecipeNet and DelfinNet.

9.3 Update the Programs "RecipeNet" and "DelfinNet"



A software update consists of one or more files or complete paths with actual file versions. The actual program version is displayed in both application programs "RecipeNet" and "DelfinNet" in the "Info" window in the field "Build" (see chapter "Information Window").



Copy the actual update files over the original files for actualization. It's important to overwrite all original files of the same name. If the Robotechnik software is in a different path than "C:\RTEU" actualize all path declarations in the configuration window for RecipeNet and DelfinNet.

9.4 Update the PLC Program

i The PLC Program boot data can only be supplied by Robotechnik.



Copy the boot data received from Robotechnik.



Replace the boot data in the machine's TwinCAT PLC boot directory `C:\TwinCAT\3.1\Boot\Plc\` by the copied boot data.



Switching the system off and on.



CAUTION!
 Unauthorized PLC boot data can cause machine malfunction or endanger the operating person. Please always contact Robotechnik before applying a PLC program update.

9.5 Basic Functions of Operating Robotechnik Software

i The user interface of the Robotechnik software works according to the general rules of MS-Windows. Knowledge of MS-Windows operation is therefore a prerequisite for operating the Robotechnik application programmes and is not described separately in this manual.

9.5.1 Virtual Keyboard

i All inputs are done by touching or clicking the touch screen or via an external keyboard with trackball. For alpha-numeric and numeric inputs a virtual keyboard is displayed on the touch screen of each Robotechnik application program. It is composed of all keys of a standard PC keyboard.

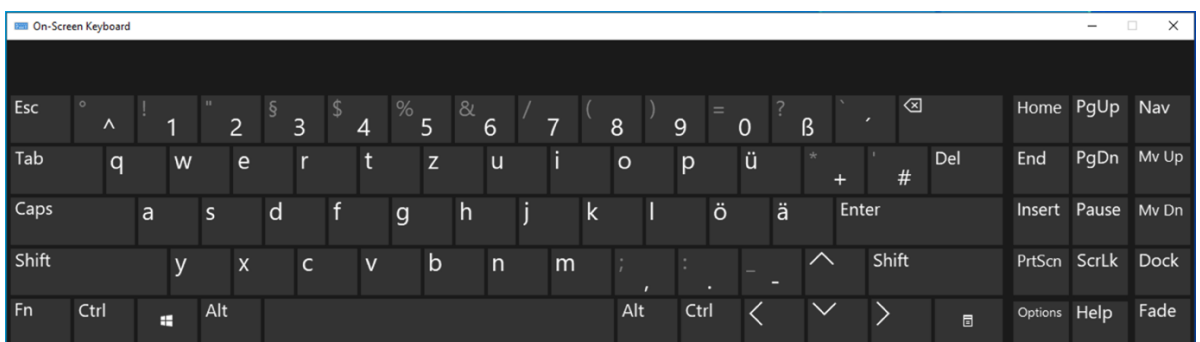



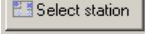
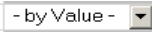



Figure 1: Virtual keyboard (example)

9.5.2 Main Input Fields in Robotechnik Software

Field	Description
	Input field (white background), alpha-numeric and numeric display
	Control button, enables or disables functions (possible multi-selections)
	Display field (grey background), alpha-numeric and numeric display
	Option field, enables or disables one exclusive option (only one selection possible)
	Command button
	List field (pull down menu), selection of one function out of several possibilities (only one selection possible)
	Scroll bar, the cursor scrolls up / down in a text or list field

9.6 RecipeNet

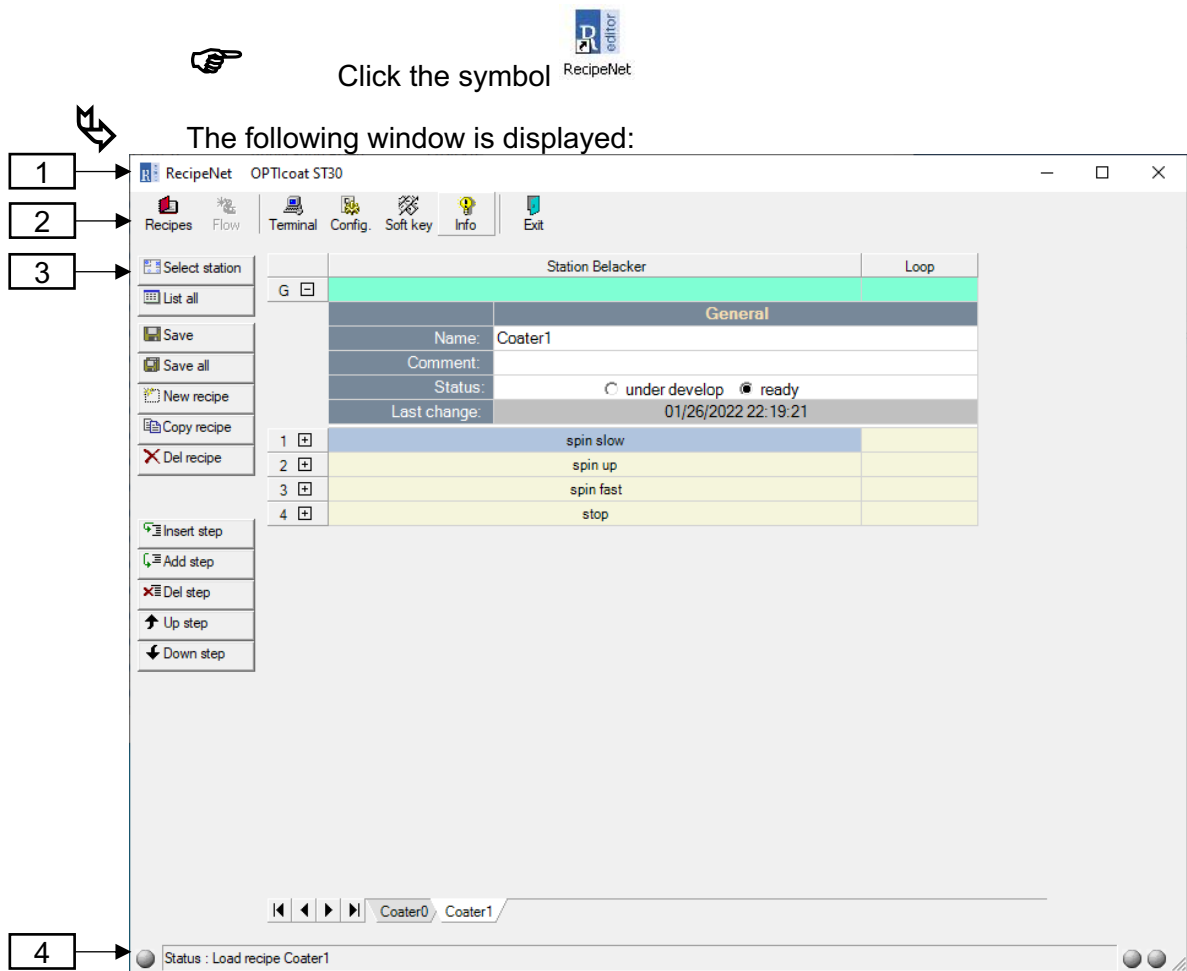

Figure 2: RecipeNet - start window

1. Column heading panel with program name
2. Toolbar
3. Operating area with function field(s) and recipe view tab(s)
4. Status information







9.6.1 Toolbar



Figure 3: RecipeNet - toolbar

The symbol buttons are displayed recessed after activation.

The following icon buttons are used in RecipeNet:

Symbol Buttons	Description
 Recipes	Recipe display - module recipe editor - creates, modifies, deletes recipes
 Flow	Disabled - only used on certain machines. Process display - module process editor - creates, modifies, deletes processes
 Terminal	Terminal window - communication with stations via commands
 Config.	Configuration window - files selection for the system configuration and virtual keyboard
 Soft key	Enables / disables a virtual keyboard on the screen (see picture virtual keyboard)
 Info	Information window - displays manufacturer's information and software version
 Exit	Finishes recipe administration - exits the program, back to the operating system

9.6.2 Recipe View - Operating Interface

After starting the recipe management, the Recipe View user interface (Recipe Editor module) is automatically loaded.
 The last recipe in alphabetic order is opened first.

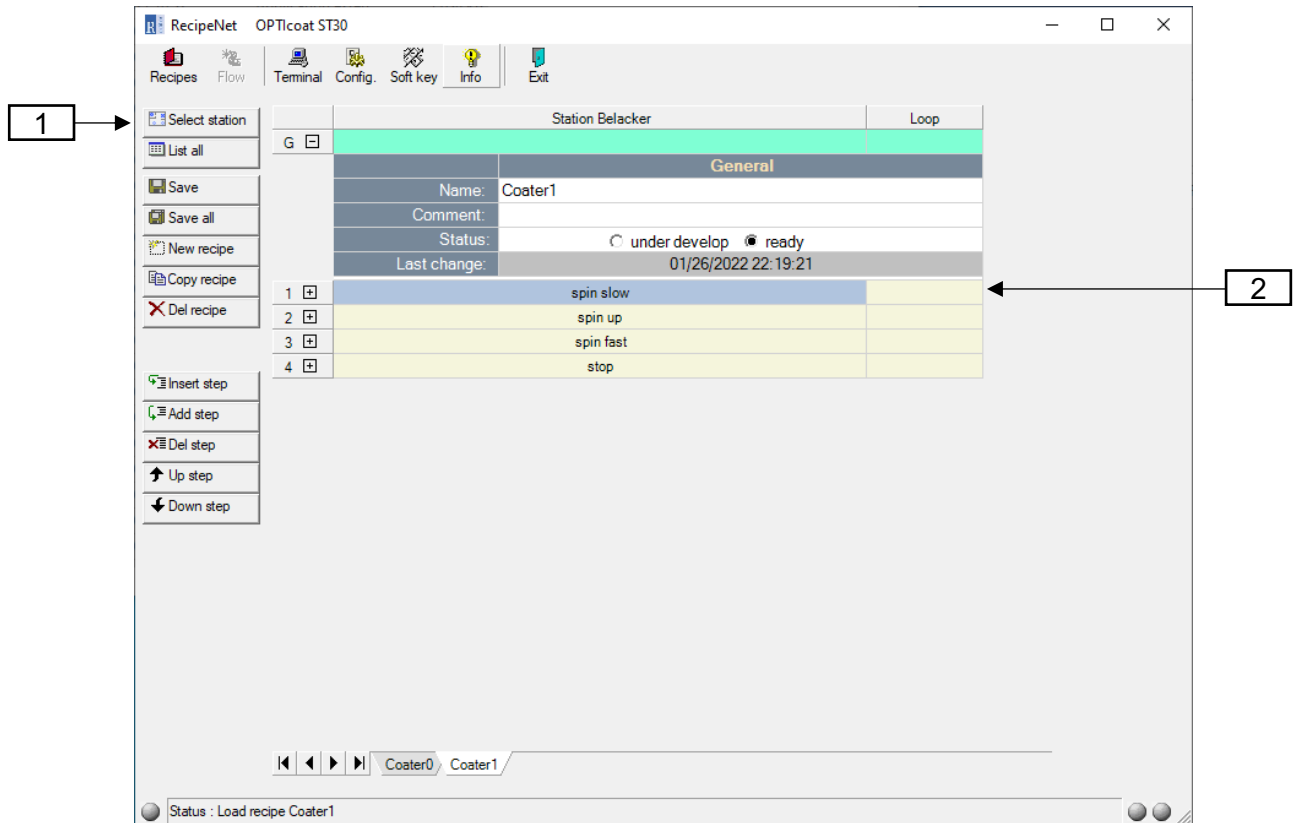

Figure 4: RecipeNet - operating interface

1. Function fields
2. Recipe view (organised in tabs)

9.6.2.1 Function Field

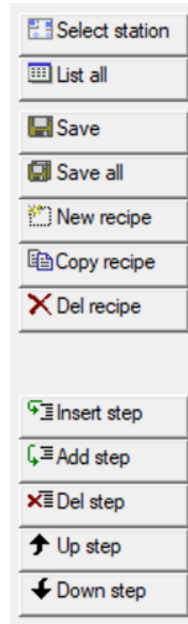

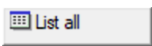

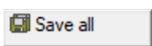
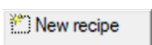
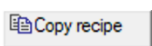
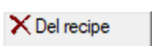
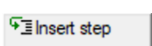

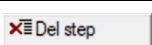
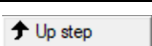



Figure 5: RecipeNet - function field recipe editor

Symbol Buttons	Description
	Selects the actual station (e.g., coating module)
	List all recipes in the predefined folder
	Save the changes to the current tab of the recipe view
	Saves all loaded recipes (tabs) in the selected path
	Creates a new recipe (tab)
	Duplicates the actual recipe in a new tab
	Deletes the actual recipe (tab)
	Inserts a new step upon the actual selected step
	Adds a new step behind the last step
	Deletes the actual selected step
	Displaces the actual selected step one step higher
	Displaces the actual selected step one step lower

9.6.2.2 Recipe View (tab)

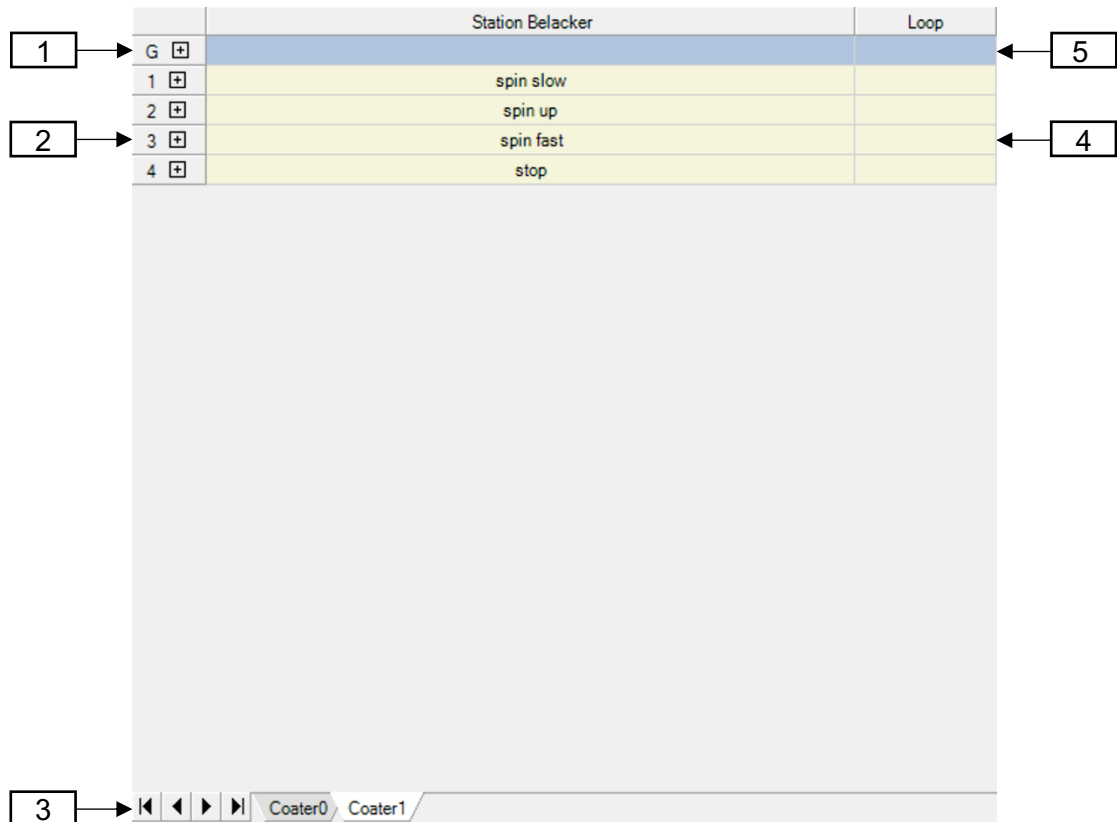

Figure 6: RecipeNet - recipe tab

1. Station name
2. List of recipe steps
3. Recipe list (white = enabled recipe) (in alphabetic order)
4. Column heading panel recipe steps
5. Column heading panel general settings (in alphabetic order)

i Each tab is a complete recipe. The tab name is also file name. Predefinition of several standard recipes simplifies later definitions of process flows.

i Clicking or opens or closes the corresponding menu.

i Each recipe consists of a “general” menu and one or more identical menus for the recipe steps.

9.6.2.3 Functions of the Menu “General”

 Click the button  the menu “General” opens. In this menu, general settings of a station are entered.

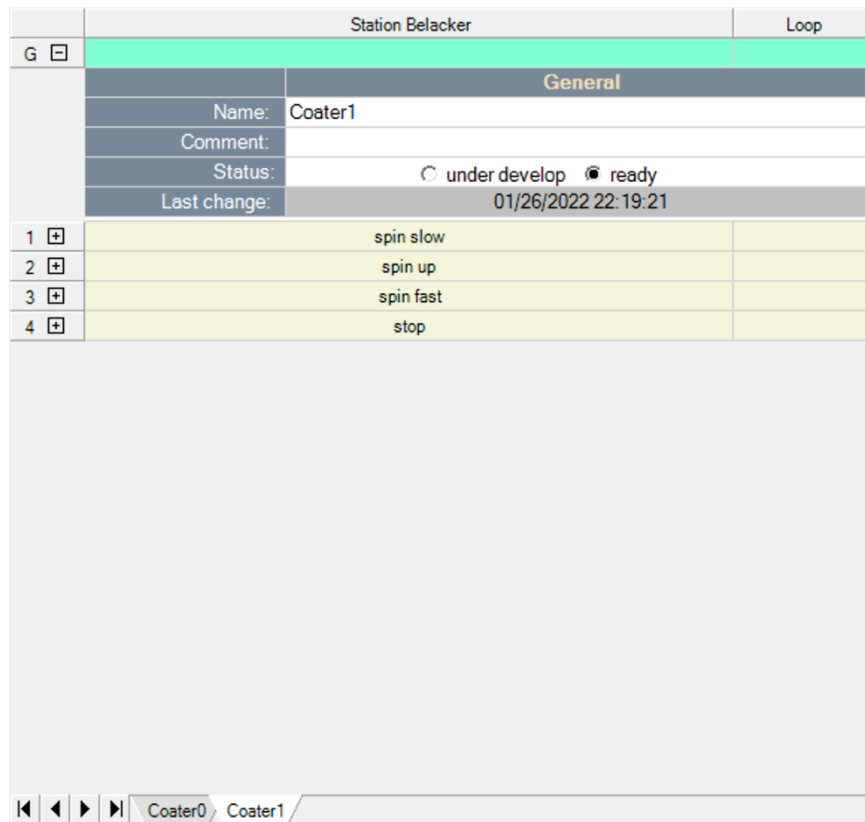

Figure 7: RecipeNet - recipe view “General”

General			
Name	Recipe name (tab name and file name)		
Comment	Comment about the menu = appears in the green headline		
Status	Option menu	Under develop	Recipe is not displayed in dialog (DelfinNet)
		ready	Recipe is displayed in dialog (DelfinNet)
Last change	Date of the last change		

9.6.2.4 Functions of the Menu “Step”

i Clicking the button  opens the menu recipe step.



Enter the settings for each recipe step in this menu.

		Station Belacker				Loop			
G									
1		spin slow							
		Recipe Step	No.	Comment			Count	Jump	
			1	spin slow					
		Analog Param.	Unit	Min.	Max.	Value	Pre. defines	Tol.	End
		Speed	rpm	0	6000	0			
		Acceleration	rpm/s	1	6000	800			
		Time	Unit	Start			Time	End	
		Steptime	s	Immediate			0.0	<input checked="" type="checkbox"/>	
2		spin up							
3		spin fast							
4		stop							

Figure 8: RecipeNet - recipe view “Step”

Recipe Step	
No.	Step number set automatically
Comment	Comment for the step headline
Count	Number of loops (-1) 1 - no repetition 2 - one repetition 3 - two repetitions etc.
Jump	Start step number of repetition

Analog Parameters	
Speed	Speed of the chuck reached as result of the acceleration and the time set
Acceleration	Acceleration of the chuck

Time	
Step time	Duration of one step. Start → immediate: start without delay End → checked: step is finished after the selected time has elapsed.

9.6.3 Recipe View - Using the Recipe Editor

i All changes to station tabs (creating, changing, deleting recipes) are only updated in the predefined path of the station (according to the configuration file) after saving by pressing the <Save> button (all recipes) or <Save recipe> (only applies on current recipe tab).

9.6.3.1 Loading Station Recipes

i When loading, all existing recipes for a station are loaded and displayed. The prerequisite is that the recipes are in the predefined path (configuration file)..

9.6.3.1.1 Schedule - Load



Click the button  in the toolbar



The field "Station" appears:

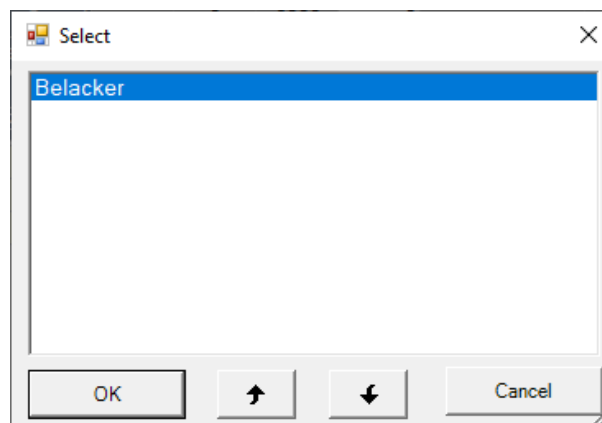

Figure 9: RecipeNet - select station



Select the required station



Confirm this action by clicking <OK>



All recipes saved of the station are displayed

9.6.3.2 Create a New Recipe

- i** You can create a new recipe on two ways:
- create a new empty recipe
 - copy an existing recipe

When you create a new recipe, an appropriate tab is displayed automatically and defined with a standard name.

9.6.3.2.1 Schedule - Create



Click the button  in the toolbar



A new recipe is displayed with the name “new recipe”

9.6.3.2.2 Schedule - Copy



Select a recipe in the recipe list

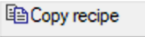

Click the button  in the toolbar



A copy of the actual selected recipe appears with the appendix “copy of ...” before the copied recipe name

Changes must be saved before they can be applied..
Without saving all modified data get lost. (see chapter “Save Recipes”).

9.6.3.3 Delete a Recipe

9.6.3.3.1 Schedule - Delete

 Select the recipe you want to delete

 Click the button  in the toolbar

 The field “System” appears:

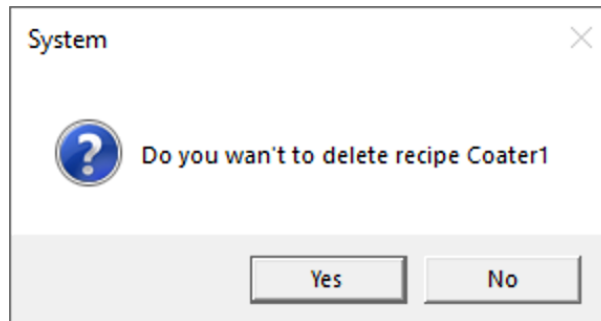



Figure 10: RecipeNet - system, delete recipe

 Confirm this action by clicking < Yes >

 The selected recipe is deleted

Changes must be saved before they can be applied.
 Without saving all modified data are lost. (see chapter “Save Recipes”)

9.6.3.4 Modify a Recipe

More information about how to operate the program and its input fields you find in the chapter [Basic Functions of Operating RTEU Programs](#)

9.6.3.4.1 Schedule - Modify

 Select the recipe you want to modify

 Select the menu “general” or the step you want to modify

 Modify the required positions

For transferring modifications save the recipe.
 Without saving all modified data are lost. (see chapter “save recipes”)

9.6.3.5 Insert, Add, Move, Delete a Recipe Step

Each recipe consists of one or more recipe steps. The menu of each recipe step is according to the station.

9.6.3.5.1 Schedule - Insert a recipe step

 Select the recipe step you want to insert a new one before (yellow column heading panel or button <+>)

 Click the button  in the toolbar



A new recipe step is inserted before the actual selected recipe step

9.6.3.5.2 Schedule - Add a recipe step

A recipe step is always added as last step.

 Click the button  in the toolbar



A recipe step is added after the last one

9.6.3.5.3 Schedule - Delete a recipe step

 Select the recipe step you want to delete (yellow column heading panel or button <+>)

 Click the button  in the toolbar



The field "System" appears:

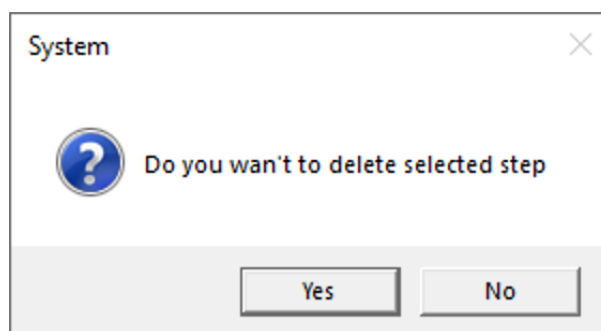



Figure 11: RecipeNet - system, delete step

 Confirm this action by clicking < Yes >



The selected recipe step is deleted

9.6.3.5.4 Schedule - Move a recipe step

 Select the recipe step you want to move (yellow column heading panel or button <+>)

 For moving the selected recipe step downwards click 

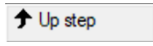
 For moving the selected recipe step upwards click 



The selected recipe step is displaced downwards or upwards.

9.6.3.6 Save a Recipe

i There are two possibilities to save a station recipe:

- Save the actual recipe
- Save all recipes

If a new tab is opened or the tab name is modified before saving, a new file with the name in the station path is created automatically.

9.6.3.6.1 Schedule - Save the current Recipe

 Click the button  in the toolbar



Only the current recipe is saved in the defined path.

9.6.3.6.2 Schedule - Save all recipes



 Click the button  in the toolbar



All recipes are saved in the corresponding path.

9.6.4 Terminal

The terminal window offers the possibility to communicate directly with each station via commands

 Click the button  in the toolbar

 The window "Terminal" appears:

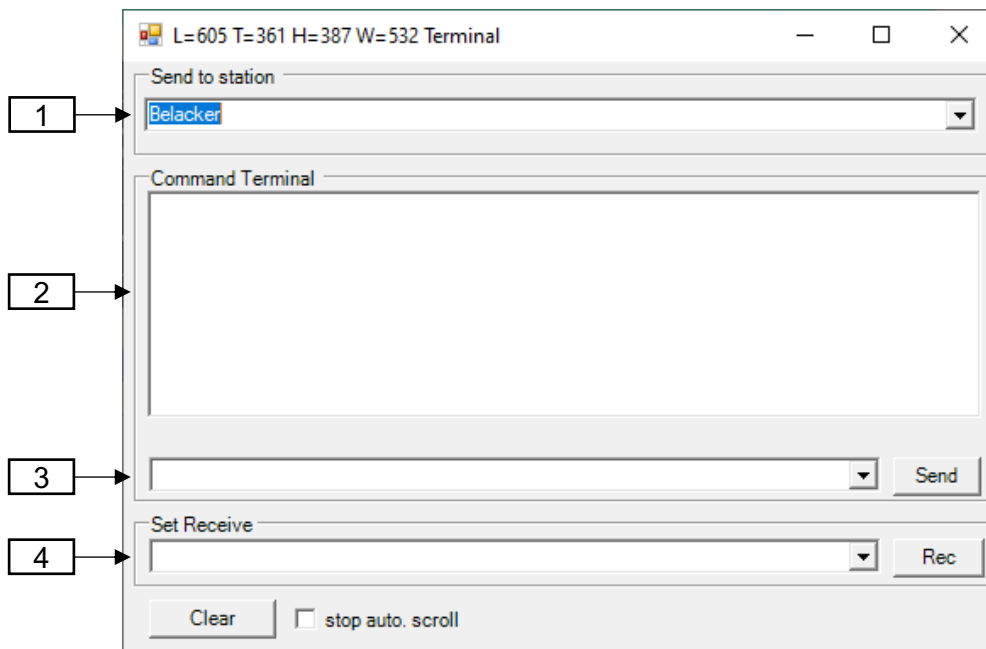



Figure 12: RecipeNet - terminal

1. Stations - Lists field
2. Display for input and output commands
3. Input line and lists field (last commands to send)
4. Input line and lists field (last commands to receive)

9.6.4.1 **Schedule - TERMINAL**

 Select the required station out of the lists field

 Enter the command in the line

 Click the button <SEND>



The activated station proceeds the command

In the display the command and a response of the system appear

9.6.5 **Configuration**

The configuration window offers the possibility to indicate the path for the system configuration and the virtual keyboard.
 A log file can be enabled or disabled.
 In addition you can arrange simulation.

 Click the button  in the toolbar.



Following window appears:

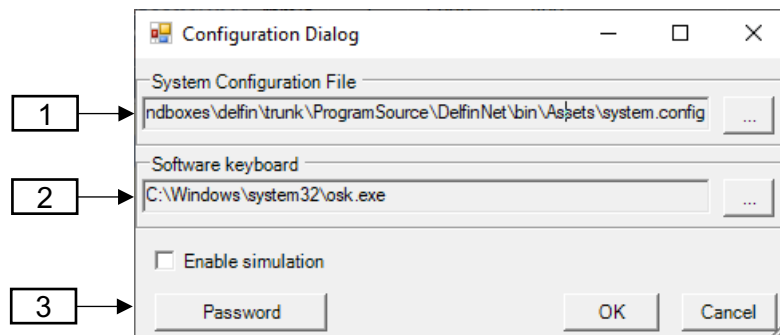

Figure 13: RecipeNet - configuration dialog

1. System configuration file - file and path indications
2. Software keyboard - file and path indications
3. Control box and password button - enable / disable

9.6.5.1 Schedule - CONFIGURATION

 Select the required display panel to modify path or file names

 Click the button 



Following window appears:

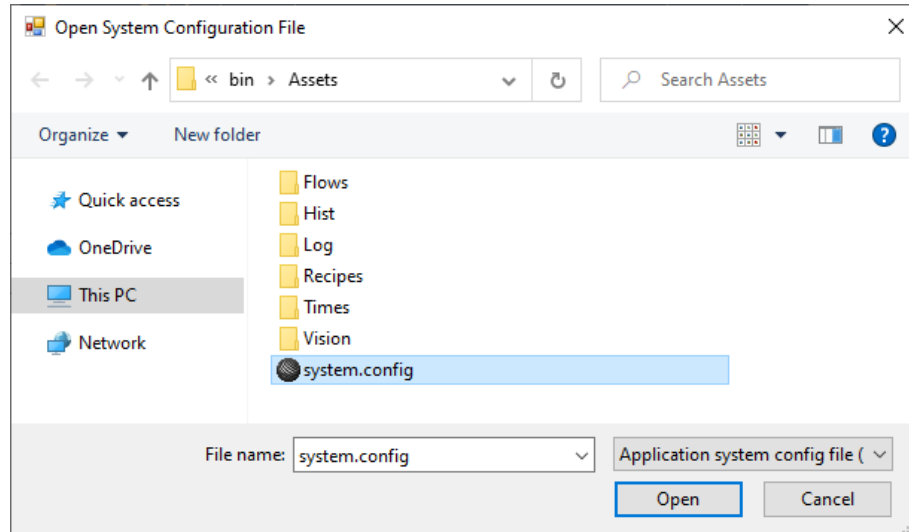



Figure 14: RecipeNet - configuration, for example, open a configuration file

 Select the required path and file in the display panel.

 Click the button <OPEN>



The configuration window with file and path indications appears in the display panel.

9.6.5.2 Schedule - Simulation

 If required enable/disable simulation by clicking the button `Enable simulation`. Simulation demonstrates several software functions without system.

Never enable simulation during a process running.

 Click the button <OK>.

9.6.6 Information Window

The information window displays the manufacturer and the software version of the recipe administration.
For updating the software it's important to inform the manufacturer about the version number (display panel 2).



Figure 15: RecipeNet - information window (example)

1. Display panel - version of the file "RecipeNet.exe"
2. Display panel - build number

9.6.7 Open Virtual Keyboard

A virtual keyboard can appear in the recipe administration for numeric and alphanumeric inputs.



Click the button  in the toolbar



A virtual keyboard appears on the touch screen (see chapter [Basic Functions of Operating Robotechnik Software](#))

9.6.8 Exit RecipeNet

Be aware!
Modifications aren't saved automatically when closing RecipeNet.



Prior to close RecipeNet, save all modifications you want to keep



Click the button  in the toolbar



If there're unsaved changes, it will show:

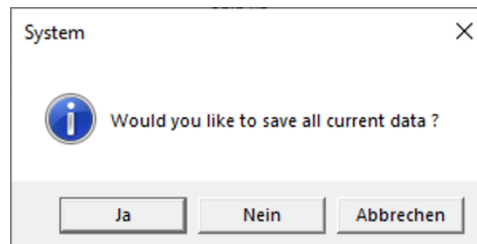

Figure 16: RecipeNet - exit application



If you want to save all changed data, please click the button "Yes", else click "No"



RecipeNet is closed.



The Windows user interface appears.



If you want to stay in the program, please click the button "Cancel".

9.7 DelfinNet



CAUTION!

Toxic vapors
Never run the system without exhaust.
Operating without exhaust can release noxious vapors that can damage parts of the system.



DANGER!

Toxic vapors
After abort of a spinning process dangerous residues could be on the substrate or in the system.
Prior to any start of a process check the process modules if there are still parts of media and clean it.



DANGER!

Destruction of the system
Prior to any initialisation and before any start of a process check the system if there are still any parts of wafer.
Check all media inputs and containers if there is any malfunction or any parts of media.
Remove all parts of wafers from each station.

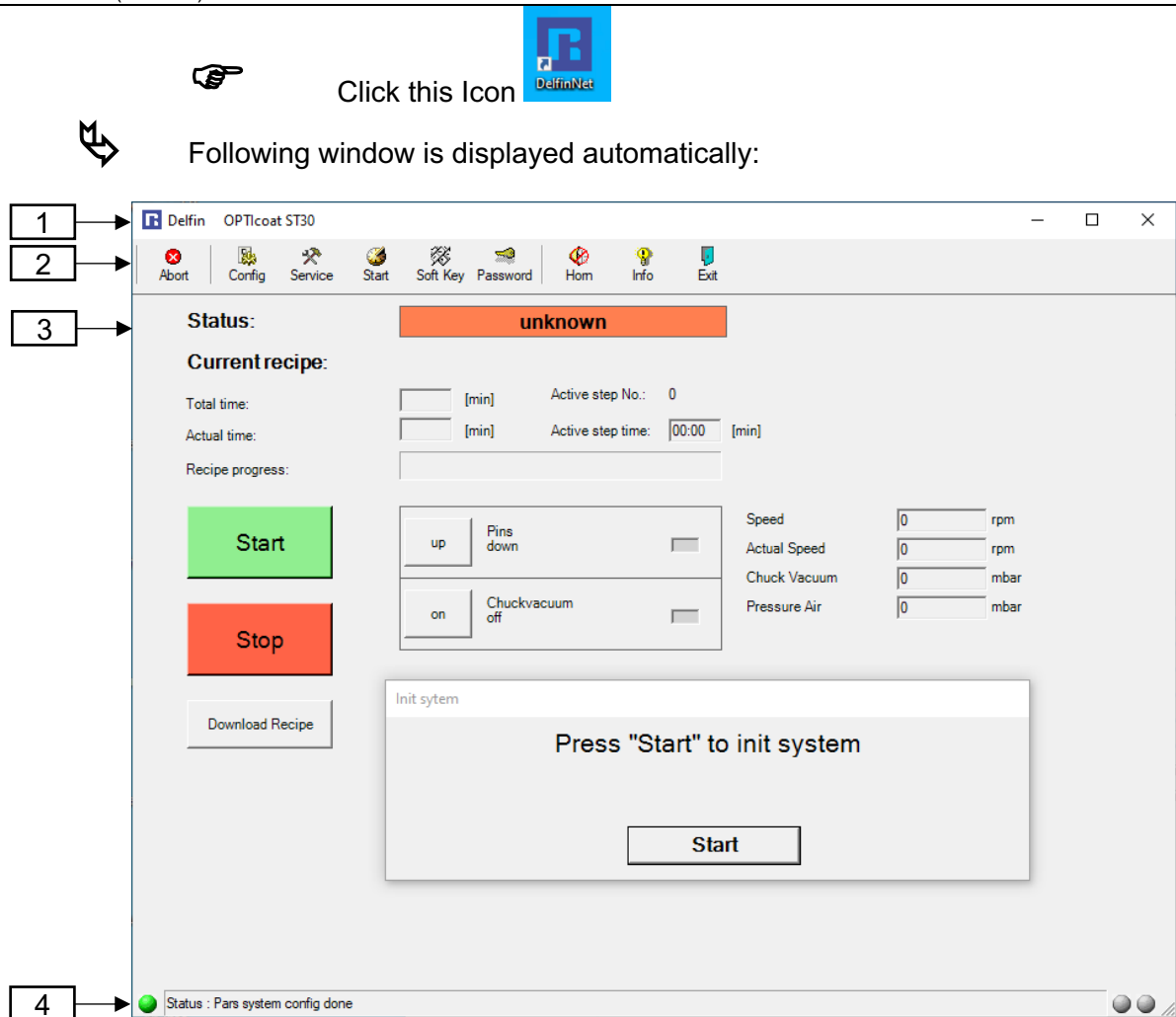

Figure 17: DelfinNet - start window











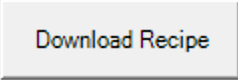

1. Column heading panel with program name
2. Toolbar
3. Operating area with station window and messages
4. Status information

9.7.1 Toolbar



Figure 18: DelfinNet - upper toolbar

The enabled symbol buttons are displayed deepened.

Symbol buttons	Description
	Starts the process
	Stops a process If the process is stopped while the machine is preparing to take the material out, a new initialization is required afterwards.
	<Download> opens the list of recipes to select for downloading. The selected recipe is indicated in the field above.
	Aborts a process After each abort, the system must be initialised again.
	Configuration window
	Opens service tasks
	Start a process with a timer (not used).
	Enables / disables a virtual keyboard on the screen.
	Opens the password display
	Enables / disables an acoustical alarm
	Information window
	Exit DelfinNet software

9.7.2 Initialisation of the System

i The system needs to be initialized on every new start, or a process is aborted, or the Emergency stop is pressed.

i After finishing a coating process, the latest status is known. A new initialisation isn't required in this case. When the station is in an unknown state, a new initialisation is required.

9.7.2.1 Function Sequence



After starting the DelfinNet software following window appears:

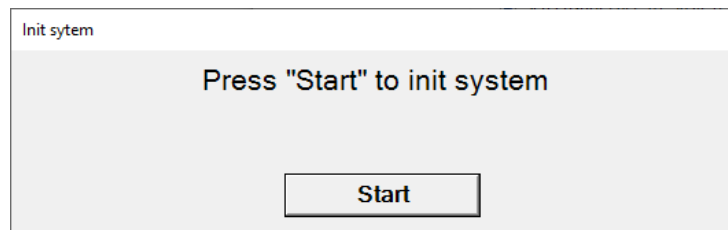

Figure 19: DelfinNet - start init



Click the button <Start>.



The stations and the robot (option) are set in a pre-defined reference position.

The indication field in the symbol list changes its background colour and indicates the status of the system.

After initialisation of all required stations the system is operational. Stations that are switched off are unknown to the system and aren't initialised.

After abort  the system must be initialised.

After stop  the system could require a new initialization if the stop was commanded while the machine was preparing to take wafer/substrate out.

9.7.2.2 Function - Initialization after Abort



Click the button



Following window appears:

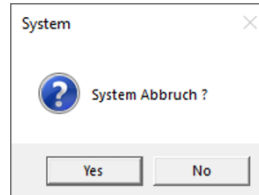

Figure 20: DelfinNet - System abort



Click the button <JA>/<Yes>



Following window appears:

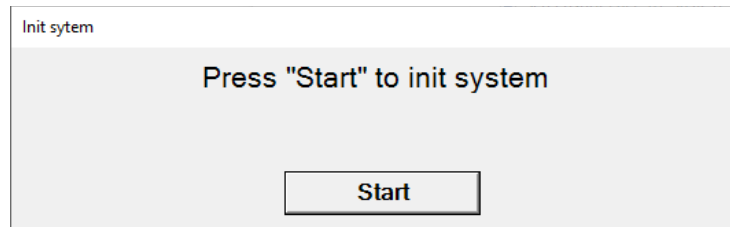

Figure 21: DelfinNet - Initialize System



Click the button <START>



The stations and the robot (option) are set in a pre-defined reference position.

The indication field in the symbol list changes its background colour and indicates the status of the system.

9.7.2.3 Function – Initialization succeeded

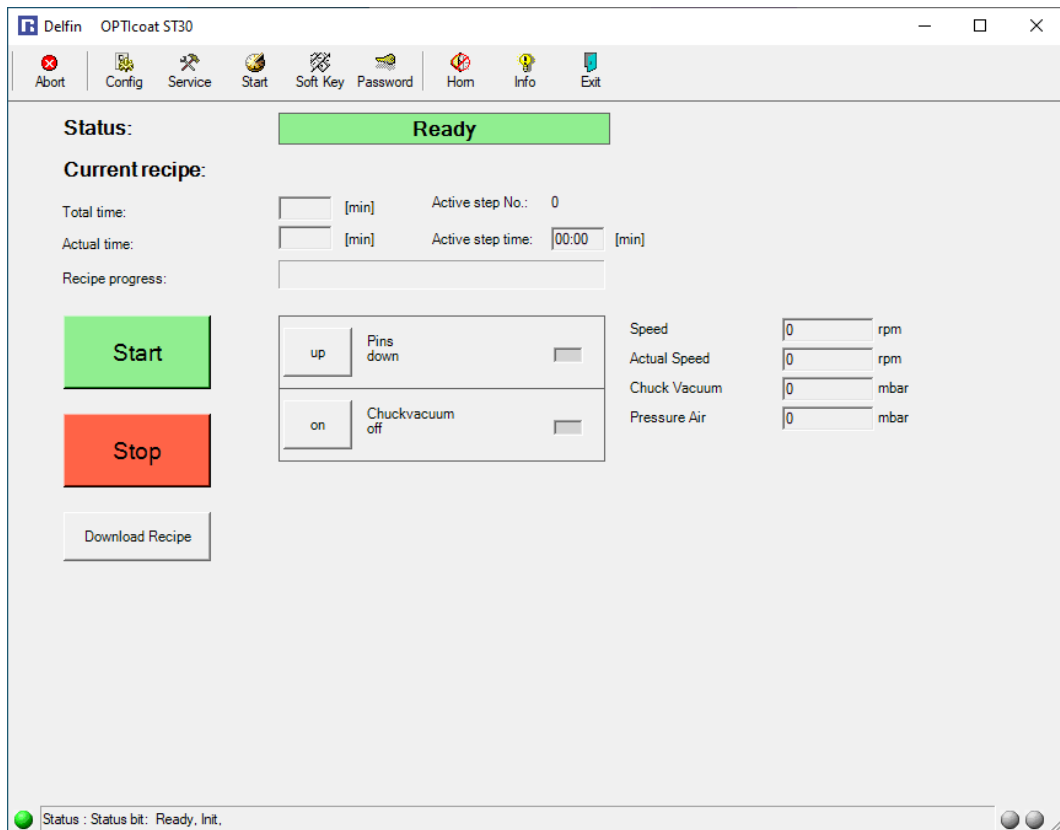

Figure 22: DelfinNet - Initialization succeeded

If the initialization has failed, please check:

- If the reset button on the electric cabinet has been pressed



- If the TwinCAT PLC is in the running state (green icon – running; blue icon - stopped)

9.7.3 Basic Functions and Parameters

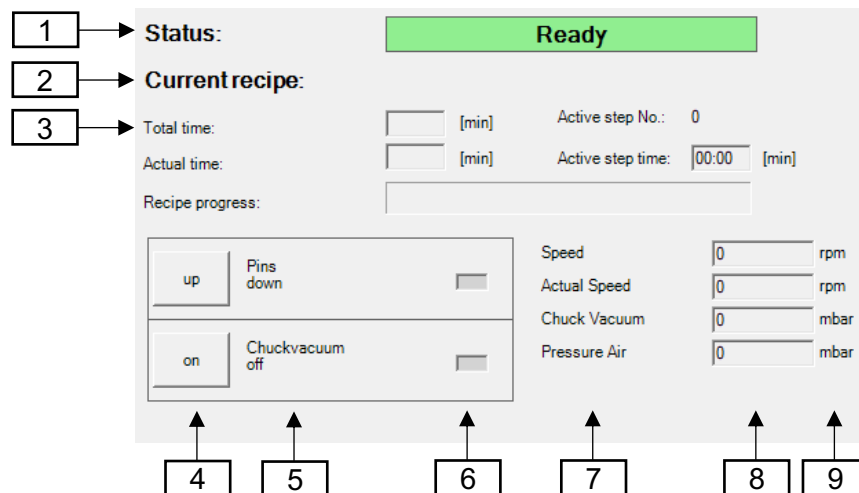



Figure 23: DelfinNet - station, tab "info"

1. Indication of the status
2. Name of the current recipe
3. Display of actual recipe parameters
4. Handling: display what happens by confirming the button
5. Handling: display of the actual command status
6. Handling: active status = coloured, inactive status = not coloured
7. Actual system parameters: parameters
8. Actual system parameters: values
9. Actual system parameters: units

Status Display	
BUSY	Process or initialisation running
READY	The system is initialised and ready for the process
UNKNOWN	The system has not yet been initialised or the process has been stopped
FINISHED	The process is finished
	Display of the process progress
Error Messages	
RETRY	Repeats the function
IGNORE	Ignores the error message
CANEL	Cancels the process

9.7.4 Configuration

The configuration window offers the possibility to define the path and the file name for the system configuration and the soft key. Depends on the machine, it may also have other functions.

The configuration can be in any device, also in the network. At this place the recipe editor edits recipes.

For this system DelfinNet and RecipeNet must use the same config file.

For the OPTIcoat ST30 machine, the simulation function is deactivated.

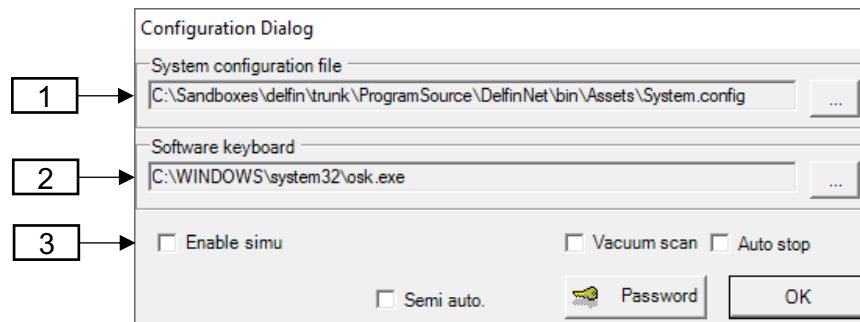
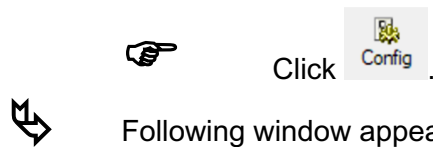





Figure 24: DelfinNet - configuration dialog

1. System config file – file and path
2. Software keyboard – file and path
3. Checkboxes - active / deactivate the specific functions.

9.7.4.1 Function Sequence – System Configuration File

 Select the desired field to change the path/file names.

 Click the button .

 Following window appears:

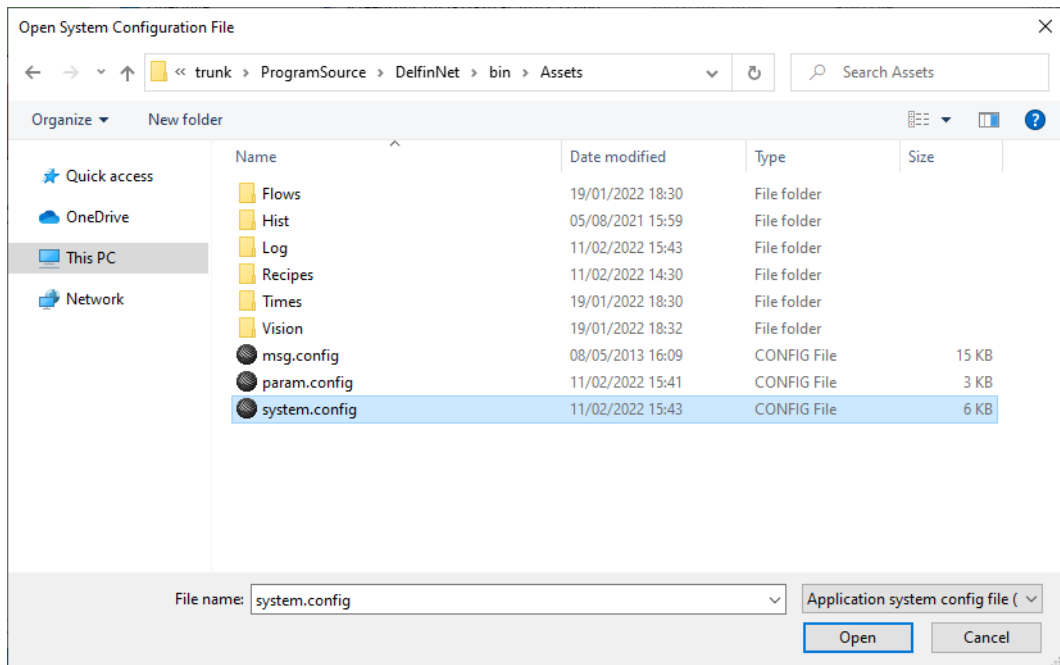



Figure 25: DelfinNet - configuration file

 Select the required path and file.

 Click the button <open>.

 The configuration window with file and path appears

9.7.4.2 Password

The service functions and the config functions are protected by a password. This can be changed at any time. Password protection is necessary due to the lack of status monitoring for these functions.

i At delivery no password is set.

i For a password protected function, it is accessible after entering the correct password.

9.7.4.2.1 Function – Enter Password

i To open the password dialogue, press the button  in the toolbar.



Following window appear:

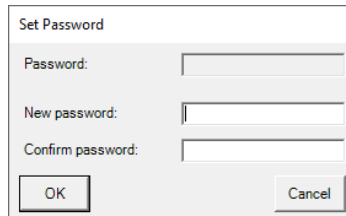

Figure 26: DelfinNet - enter password



Enter the desired new password in the input line "New password".



Enter the new password again in the input line "Confirm password".



Press the <OK> button.



The password is saved.

9.7.4.2.2 Function – Change Password



If a password has been activated, press the button  in the toolbar, following window appear:

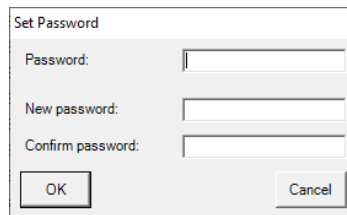

The dialog box titled "Set Password" contains three input fields: "Password:", "New password:", and "Confirm password:". Below the fields are two buttons: "OK" and "Cancel".

Figure 27: DelfinNet - set password



Enter the current password in the input line "Password".



Enter the desired new password in the input line "New password".



Enter the new password again in the input line "Confirm password".



Press the <OK> button



The password has been changed and saved.

9.7.5 Service Functions

The service mode offers the possibility to operate single functions at each station. There's no monitoring of machine status. Therefore, service functions should be password protected.



DANGER!

Injuries

The single test of functions doesn't include any security functions or queries. Danger of injuring or squeezing of body!

Only the manufacturer or qualified personnel are permitted to operate with service functions.

The manufacturer takes no responsibility for the user's service activities.

During operation with service functions any other person may not be near the system.

The service / administrator password may only be known to qualified service personnel.



DANGER!

Destruction of the system

Prior to any initialisation and before any start of a process check the system if there are still any parts of wafer.

Check all media inputs and containers if there is any malfunction or any parts of media.

Remove all parts of wafers from each station.



CAUTION!

Toxic vapors

Never run the system without exhaust.

Operating without exhaust can release noxious vapors that can damage parts of the system.



WARNING!

Destruction of the system or disfunction of the system

After finishing service functions the system doesn't know any actual states any longer. Therefore, the system must be initialised (start window).

9.7.5.1 **Service window start**



Click the button



After a password has been created, the following window is displayed:

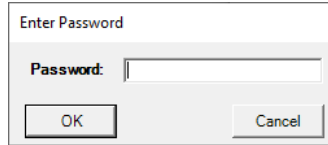

Figure 28: DelfinNet - enter password



Enter the current password in the "Password" input line



Press the <OK> button.

9.7.5.2 Service Tab - Function



After entering the correct password, the service window opens as follows:

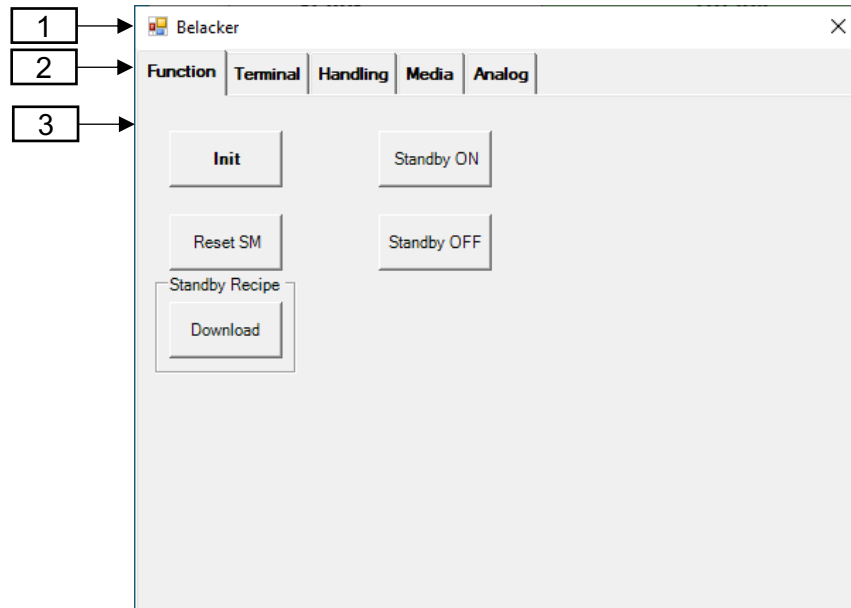

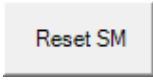
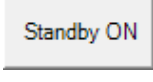
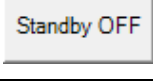
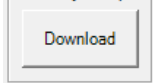

Figure 29: DelfinNet - service tab Function

1. Station name
2. Service area
3. Buttons to enable service functions

i Function and Terminal don't enable the service mode. The service mode is only activated when the subsequent tabs are selected.

Functions	
	Initialises the system.
	Step mode is disabled.
	Standby mode is enabled. (not used)
	Standby mode is disabled. (not used)
	Download of a Standby recipe, created with the recipe editor and processed after each recipe end. (not used)

9.7.5.3 Service Tab - Terminal

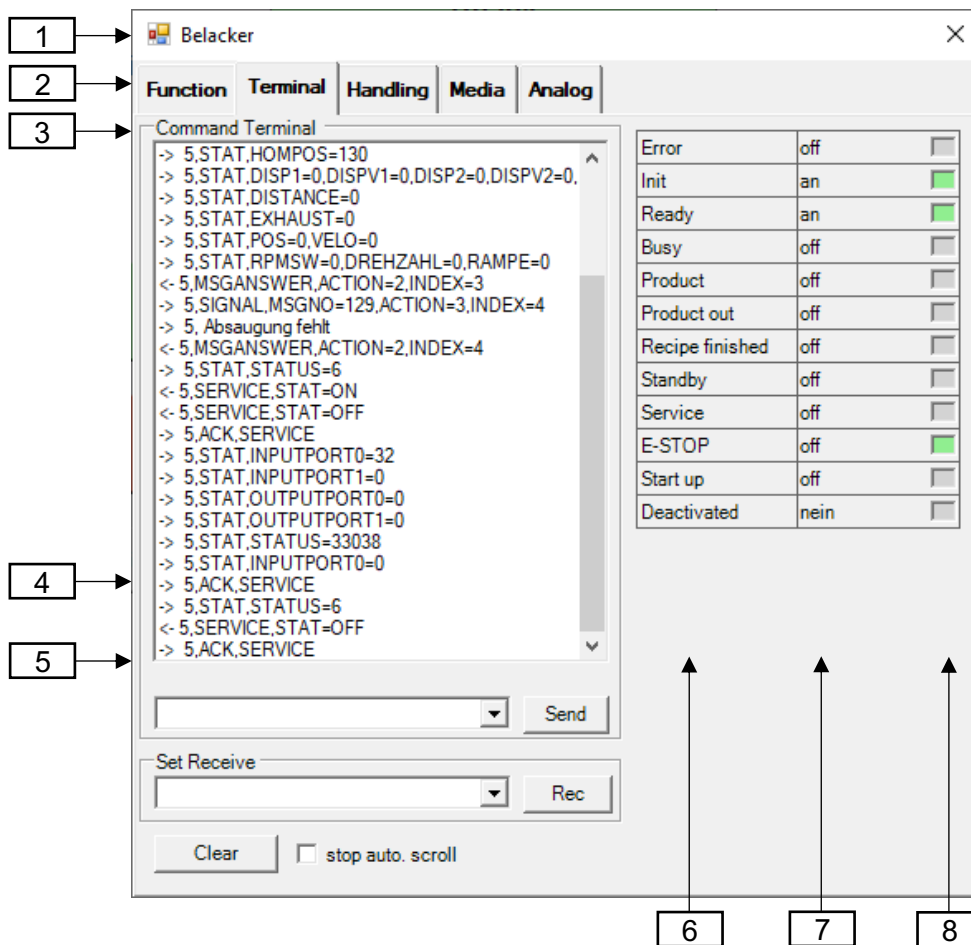

Figure 30: DelfinNet - service tab Terminal

1. Station name
2. Function selection tabs
3. Buttons to enable / disable described service function
4. Input line and lists field (last commands to send)
5. Input line and lists field (last commands to receive)
6. Sensor labels
7. Sensor status indication
8. Actual status: grey - inactive / coloured - active

9.7.5.4 Service Tab - Handling

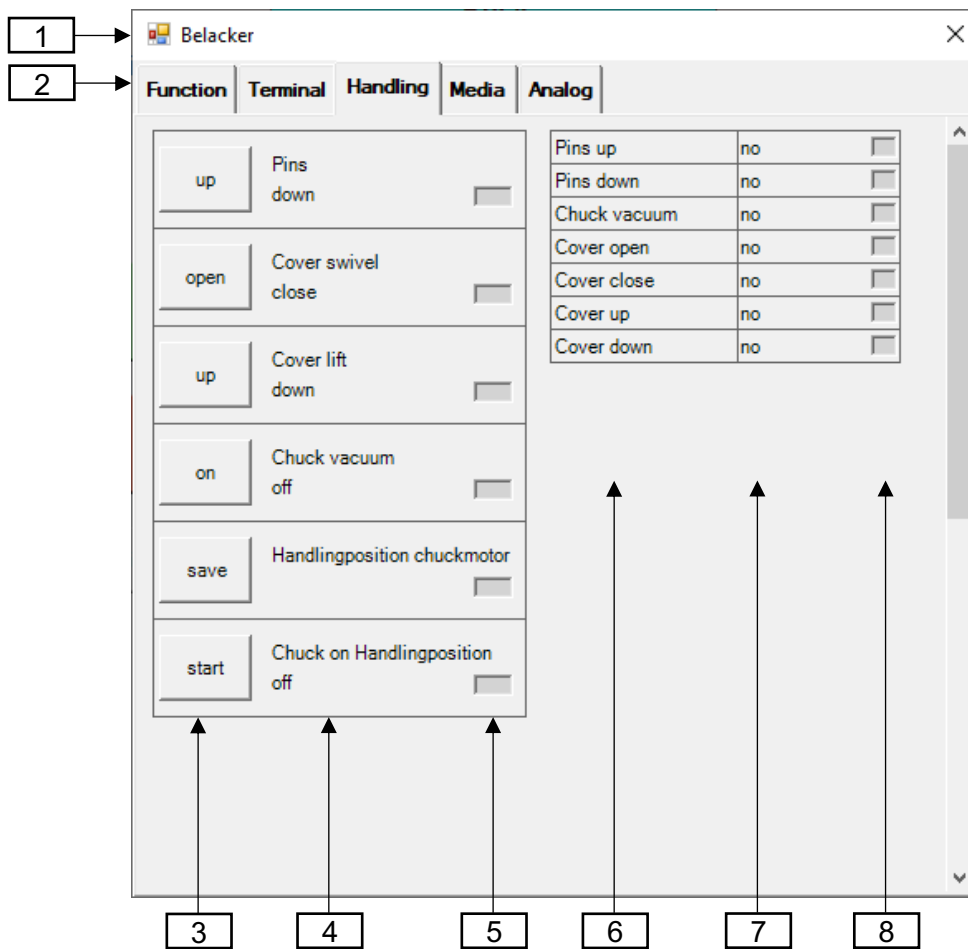

Figure 31: DelfinNet - service tab Handling

1. Station name
2. Function selection tabs
3. Indication what happens by clicking the button
4. Indication of the actual state of command
5. Actual status: grey - inactive / coloured - active
6. Description of input signal
7. Signal state
8. Signal state (grey: inactive / green: active)

9.7.5.5 Service Tab - Media

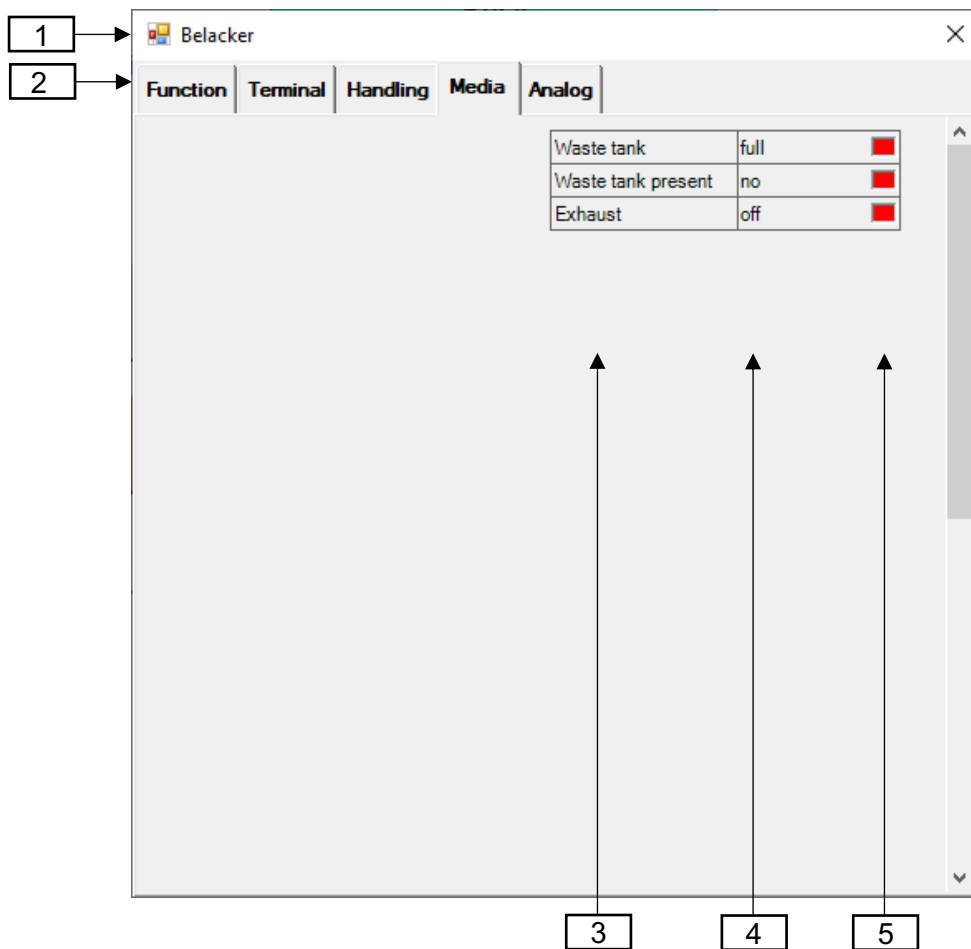

Figure 32: DelfinNet - service tab Media

1. Station name
2. Function selection tabs
3. Description of input signal
4. Signal state
5. Signal state (grey: inactive / green: active)

9.7.5.6 Service Tab - Analog Values

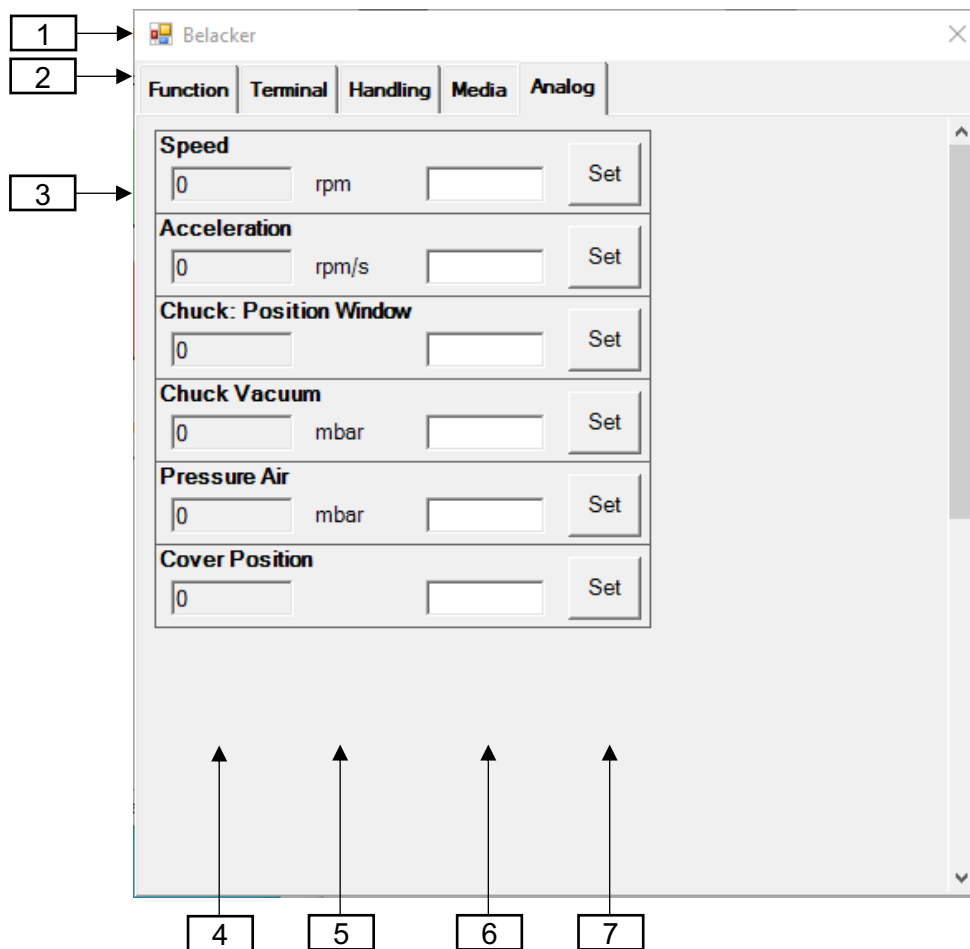



Figure 33: DelfinNet - service tab Analog

1. Station name
2. Function selection tabs
3. Display panel for actual value or state, commands to and from system
4. Actual value or state
5. Unit of the parameter value
6. Input field
7. Button to set values or commands. Clicking <SET> transfers the input text to the system.

i If your inputs are correct the system operates according to the commands and indicates the actual status in the display panel.



9.7.5.7 Service exit

The enabled symbol  is displayed deepened, if the service window is open.



WARNING!
Destruction or malfunction of the system.
After the service functions have been completed, the system no longer knows any current states. Therefore, the system must be initialised.

9.7.5.7.1 Function Sequence – Service Exit

Click the button  in the toolbar or the close button  of service window.



The DelfinNet Init System window appears. If it does not appear, click the  button on the toolbar.



If service values should be set, click <SERVICE> again, because otherwise the system doesn't recognize any modifications, entered via service

Prior to start the system must be initialised (see chapter [Initialisation of the System](#))

9.7.6 Open Virtual Keyboard

A virtual keyboard can be opened in the DelfinNet for numeric and alpha-numeric inputs.



Click the button



A virtual keyboard appears on the monitor (see chapter [Basic Functions of Operating Robotechnik Software](#))

9.7.7 Horn

Depends on the machine configuration, a Horn may be or may be not included.

During operation it can be advantageous to enable an acoustic alarm in addition to the visual error message, e.g., during operating without intervisibility to the system. This horn can be switched off after activation.

9.7.7.1 Function sequence



Click the button



The acoustic alarm is switched off.

Switching the alarm off refers only to the actual error message. Continuing the process the alarm is operational again.

9.7.8 Information Window

The information window gives details of the manufacturer and the software version.

For updates of the software, the Build number (display field 2) must be given to the manufacturer. This version number is automatically generated when the software is created.

 Click the button  in the toolbar.

 Following window appears:

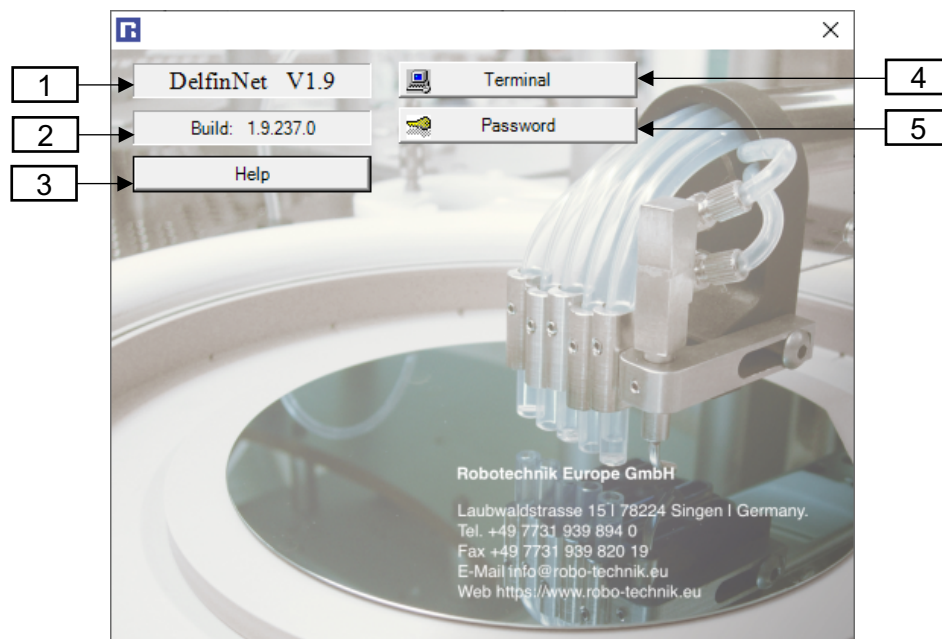



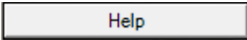



Figure 34: DelfinNet - information window (example)

1. Window - Version of the file "DelfinNet.exe"
2. Window - Build number (important for software updates)
3. Button - Help (how to open operating instructions)
4. Terminal – Open the Terminal window
5. Password – Set a new password

9.7.8.1 Open the Operating Instructions

The complete operating instructions can be displayed on the monitor. You can jump directly to the required chapter via clicking the marginal list of contents (Adobe Reader application).

Function sequence - Open the Operating Instructions:

-  Click  on the information window to open the operating instructions
-  Adobe Reader runs, the operating instructions appears
-  Any further application is done in Adobe Reader
-  After finishing Adobe Reader, you return to the information window





9.7.8.2 Terminal

The Terminal window offers the possibility to contact each station by input commands. Note all safety instructions about the system and its software. Therefore the Terminal window is password protected.

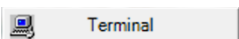

DANGER!

Injuries
 All Terminal commands run without status control. Only qualified personnel is allowed to operate Terminal functions.
 All actual states of system and software must be known.

-  Click  in the info Window
-  Enter the actual password in the input field "Password"
-  Click the button <OK>
-  Following window appears:

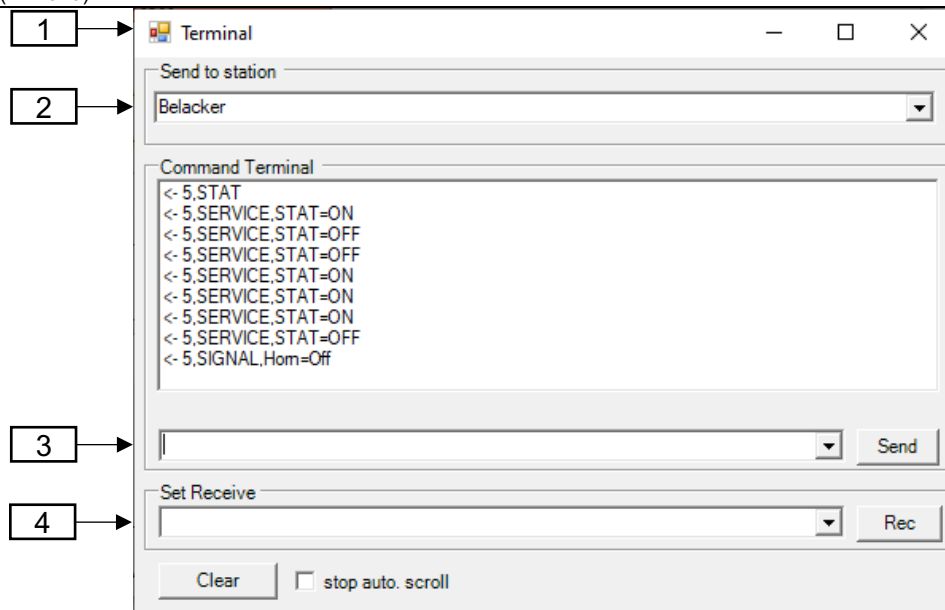



Figure 35: DelfinNet - terminal window

1. Selection of station - list field
2. Window for input and output commands
3. Input line and lists field (last commands to send)
4. Input line and lists field (last commands to receive)

Function Sequence:

 Select the required station in the list field.

 Input the command in the input line

 Click the button <Send>

 The responded station executes the command.

 The input command and a re-command from the system appear in the field.

Last commands can be selected in the list field.
 All commands are deleted after exit DelfinNet.

9.7.8.3 Password

 Click the Password button  on the information window to set/change password. (See [§9.5.3.2](#))

9.7.9 Exit DelfinNet



Click the button



Following window appears:

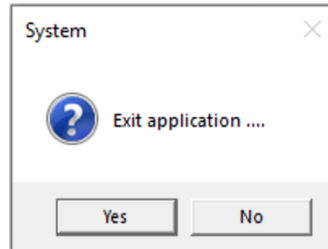

Figure 36: DelfinNet - exit



Click the button <Yes>



DelfinNet is finished



The Windows operating surface appears

10 Cleaning





Table of Contents

	Page:
10.1 Cleaning in General	2
10.2 Cleaning the Process Bowl	3

i The OPTIcoat ST30 doesn't need any special maintenance, except occasional cleaning. Cleaning intervals depend on usage intensity and the type of applied media.



Do not use scratching or scouring cleaning agents or tools.

	DANGER! Prior to cleaning work inside the unit, the unit and additional modules have to be disconnected from all external and media supplies. Pay attention to all additional safety instructions in chapter Safety Instructions
	DANGER! Danger due to electricity! Only clean the system when it is de-energised.
	DANGER! Danger due to electricity! Do not use dripping wet cloths or high-pressure cleaners to clean the system.
	DANGER! Danger of destruction of system components When cleaning the system and components of the system, do not use any solvents that have a corrosive or destructive effect.

10.1 Cleaning in General



Clean the chuck, the process chamber and the process chamber (interior) with DI water or a solvent which is suitable for the process chemical.









Clean the stainless-steel surfaces, the armatures and the cabinet only with alcohol or equal solvents.



Rinse the hose lines (media lines and exhaust hoses) with a suitable cleaning agent if necessary. This cleaning agent depends on the process media previously used and must not harm any system components.

10.2 Cleaning the Process Bowl

- i** Remove the chuck for cleaning the process bowl.
-  Draw the chuck vertically upwards out of the motor shaft.
-  Remove the cover ring and the splash ring.
-  Remove the process bowl slowly vertically upwards.
-  Clean all components with a suitable medium.
-  Reassemble the process bowl with its cover ring and splash ring.
-  Place the process bowl between the pins on the base plate.
- i** Assure that all components lie flat again.
-  Place the chuck on the motor shaft.

1. Remove the chuck

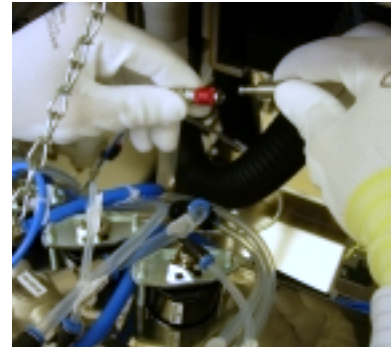

2. Remove the splash ring

3. Disconnect the BSR pipe
(if the machine is equipped with)

4. Remove the inlay

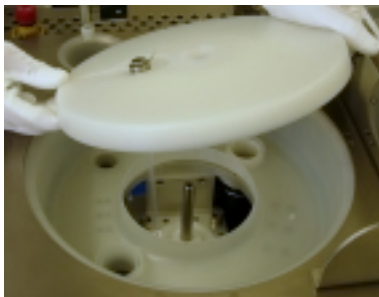

5. Remove the bowl



11 Maintenance

Table of Contents

	Page:
11.1 Maintenance Guidelines	2
11.2 Emptying the Media Waste Bottle	3
11.3 Emptying the Inspection Glass for Vacuum System	3
11.4 Daily Maintenance	4
11.5 Weekly Maintenance	4
11.6 Monthly Maintenance	4

11.1 Maintenance Guidelines



DANGER!

Cleaning the chuck!

Clean the installed chuck with a suitable detergent, otherwise unsuitable solvent could destroy the motor.



DANGER!

By applying components of other manufacturers additional and unknown hazards may arise. No liability will be taken in this case.

Use only genuine parts provided by the manufacturer of the system.

Genuine parts are constructed conforming to applicable safety regulations.



DANGER!

Moving parts may cause squeezing or cutting of extremities.

Do not touch any moving parts of the system while in operation.



DANGER!

Maintenance and servicing work may only be carried out by specially qualified personnel.





DANGER!

Operation of the system by several persons may cause hazards based on misconduct or missing mutual understanding.

Operation of the system by two or more persons is not allowed.









If in case of service or maintenance tasks the system has to be operated by two persons, these have to conduct a secure joint procedure.

11.2 Emptying the Media Waste Bottle

- i** The media waste bottle must be emptied when it's filled up to 9/10.
-  Turn the media waste bottle out (right-hand thread).
-  Empty the media waste in a suitable special waste container.
-  Turn the media waste bottle again on the connection pipe.

**DANGER!**
Emptying may only be carried out when the machine is stationary and never during operation.

11.3 Emptying the Inspection Glass for Vacuum System

- i** Whenever you empty the media waste bottle you also clean the media inspection glass required. The glass is below the motor of the spin chuck.
-  Disconnect the system from the vacuum supply.
-  Unlock the screw under the vacuum inspection glass.
-  Pull the fastening bow sideward.
-  Take the vacuum inspection glass out and empty its content into a suitable special waste container.
-  Clean the vacuum inspection glass.
-  Press the vacuum inspection glass back into the nut. Make sure that the seal is placed correctly.
-  Push the fastening bow under the vacuum inspection glass and fix the screw.
-  Reconnect to vacuum supply.
-  Place a substrate on the chuck, turn the vacuum on and control the tightness around the vacuum inspection glass.

**DANGER!**
Emptying may only be carried out when the machine is stationary and never during operation.

11.4 Daily Maintenance

Code: 1 = check 2 = clean 3 = adjust 4 = replace 5 = lubricate

Check Point	Designation	Code	Action	Information
	Media separator for vacuum system at the motor	1	<ul style="list-style-type: none"> Fill Level - emptying if necessary 	

11.5 Weekly Maintenance

Code: 1 = check 2 = clean 3 = adjust 4 = replace 5 = lubricate

Check Point	Designation	Code	Action	Information
	Process bowl, splash ring, chuck and covered chuck lid on the coater	2	<ul style="list-style-type: none"> Cleaning with suitable solvent 	Note media resistance of components.
	Drip pan	1 / (2)	<ul style="list-style-type: none"> Checking, cleaning with a suitable solvent if necessary. 	Note media resistance of components.
	Piping	1	<ul style="list-style-type: none"> Stability and tightness 	
	Sensor connection	1 / (3)	<ul style="list-style-type: none"> Plug connections - retightening if necessary 	
	Pressure regulator	1 / (3)	<ul style="list-style-type: none"> Check the pressure adjust it if necessary 	Assure that the pressure is not above 2.5 bar. To read the real pressure value, it is necessary to put the machine in service mode and close the process lid.
	Front panel and side panels	2	<ul style="list-style-type: none"> Checking and cleaning with suitable solvent 	

* Dependent on media - the maintenance rate depend on media and the system's operating life.

11.6 Monthly Maintenance

Code: 1 = check 2 = clean 3 = adjust 4 = replace 5 = lubricate

Check Point	Designation	Code	Action	Information
	Piping	1	<ul style="list-style-type: none"> Checking tube connectors, screwing fittings and retorque if necessary 	

i This maintenance rate applies for 1-shift operation.

12 Trouble Shooting

Table of Contents

	Page:
12.1 Trouble Shooting Guidelines	2
12.2 Trouble Shooting	3

12.1 Trouble Shooting Guidelines



DANGER!

Cleaning the chuck!

Clean the installed chuck with a suitable detergent, otherwise unsuitable solvent could destroy the motor.



DANGER!

By applying components of other manufacturers additional and unknown hazards may arise. No liability will be taken in this case.

Use only genuine parts provided by the manufacturer of the system.

Genuine parts are constructed conforming to applicable safety regulations.



DANGER!

Moving parts may cause squeezing or cutting of extremities.

Never reach into the switched-on system with your hand or any other part of your body.



DANGER!

Trouble shooting work may only be carried out by specially qualified personnel.



DANGER!

Operation of the system by several persons may cause hazards based on misconduct or missing mutual understanding.

Operation of the system by two or more persons is not allowed.

If in case of service or maintenance tasks the system has to be operated by two persons, these have to conduct a secure joint procedure.

12.2 Trouble Shooting

There is no vacuum on the chuck and/or an error appears.

- Is the vacuum connected?
- Is the vacuum sufficient?
- Is the vacuum controller connected correctly and/or adjusted correctly?
- Is the substrate correctly positioned?

The media does not flow out of the process bowl.

- Drain in the process bowl clogged?
- Is the waste container full sensor adjusted correctly?

No actuator voltage available.

- Is the emergency stop disengaged?
- Sensor triggered (e.g. leakage)?

Exhaust does not work.

- Check hose between differential pressure monitor and the exhaust tube
- Check the value set on the differential pressure monitor.

Recipe does not run correctly.

- Are the end conditions set?
- Error in the program sequence

13 Disposal

Table of Contents

	Page:
13.1 Disposal of the System.....	2
13.2 Disposal of Chemicals.....	2

13.1 Disposal of the System

i At the end of its life span the system has to be disassembled and disposed according to applicable laws and regulations.



Upon disposal, consider the following:

- Separate materials.
- Forward metals to a recycling process.
- Forward plastic parts to a recycling process.
- Forward electrical/electronic parts to a special waste disposal process.

Recommendation: Get in contact with a waste disposal professional.

13.2 Disposal of Chemicals

i Chemicals used in processes or cleaning must be disposed according to applicable laws and regulations.

Recommendation: Contact a specialist company that specialises in disposal.

14 Spare Parts List

Artikel Nr. Part No.	Kurztext Part Description
833231	Sensor magn. D-A93L24VDC/40mA/3m Reed switch D-A93L24VDC/40mA/3m
833480	Drosselrückschlagventil Abluft M5-ID4 One way restrictor exhaust air
833674	Füllstandssensor kapazitiv Capacitive Fill Level Sensor
834394	Druckfeder 0.8x6.3x23 A2 VD130 Pressure spring 0.8x6.3x23 A2 VD130
834888	Schauglas und Dichtung Gage glass and seal
836848	O-Ring 19x3 DIN3770 EPDM 70 shore O-seal 19x3 DIN3770 EPDM 70 shore
837061	Dichtring 1/8" PVC hart Seal ring 1/8" PVC hard
839728	Wellschlauch 13,8x17,8 PFA/Teflon(f.3/4□) Corrugated tube 13,8x17,8 PFA/Teflon
839867	SIGNALGEBER REED-SCHALTER MIT LED Signal transmitter reed switch with LED
843351	Gegenlager für SMC zyl. C85 SAP (22352) Counter bearing for SMC cyl, C85 SAP (22352)
847030	Drosselrück.ventil m. Pilotventil R1/8□ One-way restrictor with pilot valve
860446	Kompaktschlitten D=12; Hub=75 Compact slide D=12; Hub=75
860450	Abhebestift 4x85 Lift off pins 4x85
860452	Auflage Substrat Ø4x3 PEEK Support substrate Ø4x3 PEEK
861324	Zylinder pneu. D=25 / Hub=60

Artikel Nr. Part No.	Kurztext Part Description
	Cylinder pneu. D=25 / Hub=60
862013	Kompaktschlitten D=25; Hub=100 Compact slide D=25; Hub=100
862019	Abfallkanister 5L HD-PE Weiss Waste canister PP white 5l
868939	O-seal, Ringschnur d2=2.5mm / d1=320mml, EPDM O-seal, endless d2,5xDi320 EPDM
869677	Gelenkkopf di=10, M10links Rod ends with plain bearing di=10, M10 left
871248	AC-Servomotor 4M504E AC-Servomotor 4M504E
877489	QUINT-PS/1AC/24DC/10 Power supply 10A/24V DC
100599	Industrie PC (IPC) Industrial PC
100004	IPC Motherboard-Batterie CR2032 IPC motherboard battery CR2032
100598	Touch display 12"
100600	Ethercat Smart servo Ethercat Motor controller
868891	Auffangtopf, PP Process bowl PP
868893	Spritzring Di=370 H=42, PP Splash ring Di=370 H=42, PP
868894	Einlegering, D=380 Di=125, PP Insert ring D=380 Di=125, PP
873552	Abfluß a=118, Di=32,6, L=130, PP Drain a=118, Di=32,6, L=130, PP
862004	Absugschlauch ID38-AD41.2 Drain hose ID38-AD41.2
878446	Teflonfolie für Deckel innen Teflon foil for inner cover

Artikel Nr. Part No.	Kurztext Part Description
100616	QUINT4-PS/1AC/12DC/2.5/PT Power supply 2.5A/12V DC
866623	O-seal 18.77x1.78 DIN3770 FPM
875693	Chuck Basic 12" Sx30 -M-PV
871585	Inlay vc 6" Wafer -M—V
875726	Inlay 8" Wafer -M—V
875723	Inlay 12" Wafer und 9x9" Subst.
100614	Inlay 9" Wafer -M--V
868951	Deckel innen Inner processing cover

15 OEM Manuals

Further OEM manuals are available on request.